



STT SERIES SEALED TILT SENSORS

INNOVATION IN MOTION

The Penny+Giles STT series of sealed tilt sensors have been designed to provide reliable, fit-and-forget tilt measurement sensing for the most arduous operating environments. The STT280 is supplied in a compact 28mm diameter body with crush proof inserts in the mounting flange. The larger STT500 is supplied in a rugged, marine grade cast aluminium housing.

These tilt sensors are suitable for use in applications such as road construction equipment, cranes and booms, scissor lifts, agricultural vehicles, container handling and hydraulic lift systems.

The STT series use solid state 3D-MEMS (Micro-Electro-Mechanical Systems) technology to measure the sensor's inclination relative to earth's gravity. They have a measurement range from $\pm 10^\circ$ to $\pm 60^\circ$ and provide a 0.5 to 4.5Vdc output signal over these angular ranges, with a nominal 2.5Vdc at 0° tilt. By using this technology, the STT series provide distinct advantages in reliability, stability and compactness over fluid based, electrolytic and pendulum operated sensors.

Highly robust, maintenance-free and easy to fit, the Penny+Giles STT series sealed tilt sensors represent cost-effective solutions for demanding tilt measurement applications.



Features

- No moving parts
- High resolution $\pm 0.07^\circ$
- Absolute measurement
- Measuring range from $\pm 10^\circ$ to $\pm 60^\circ$
 - Less than 6.5mA supply current
- Choice of compact or rugged styles
 - Protection up to IP69K
- Rapid dispatch of any option
- CE approved

Benefits

- Virtually infinite life
- Capable of sensing the smallest displacement
- No loss of tilt position on power down
- Maximum sensitivity in all applications
- Low power consumption
- Suitable for extreme environments
- Operation in hostile environments including pressure washing
- Eliminates customer inventory
- Confidence in EMC performance



EMC Directive 2004/108/EEC

The products detailed in this document have been tested to the requirements of EN 61000-4-3

RoHS Directive 2002/95/EEC

The products detailed in this document comply with the RoHS (Restriction of use of certain Hazardous Substances in Electrical and Electronic Equipment) directive 2002/95/EC.



Quality Assurance

Penny+ Giles are accredited to BS EN ISO9001:2008. Quality is at the heart of all our systems ensuring the reliability of our products from initial design to final despatch.

Certificate No. LRO 0924881

Design Statement

The design of model STT500 is subject to Community Registered Design No 000961610-0002

The STT280 and STT500 designs include an Input Protector Circuit (Patent Applied For).

STT series SEALED TILT SENSORS

Innovative, rugged design – superior protection

The STT series have been designed to offer the best combination of materials and mounting styles that ensure survivability in the most rugged applications. We use sealing systems and cable connections that offer superior protection against the most hostile of operating conditions.



Impressive environmental capability

The STT series have been designed with 21st century applications in mind. The STT280 housing is manufactured using high strength corrosion resistant materials and has a protection rating of IP68. The STT500 housing is manufactured using a marine grade aluminium casting and can be supplied with a protection rating to IP69K. Both tilt sensor models can withstand operating temperatures from -40°C to +125°C and have been tested to withstand a 3m drop onto concrete (maximum 20,000g). With an EMC Immunity of 100V/m, these tilt sensors are ready for the harshest applications.



Choice of operating voltages

The STT280 and STT500 can operate from a 5Vdc regulated or 8 – 30Vdc unregulated power supply.

- At 5Vdc the sensor operates from a regulated supply in the range 4.75 to 5.25Vdc and provides a ratiometric output which is 80% of V_{supply} over the selected full range angle of tilt, with 50% of V_{supply} at 0° tilt.
- Between 8 – 30Vdc the sensor will operate from an unregulated supply in the range 8 to 30Vdc. The sensor has an internal voltage regulator and provides an output that is absolute and 0.5 to 4.5Vdc over the selected full range angle of tilt, with a nominal 2.5Vdc at 0° tilt.

The sensor circuit has a low supply current level of less than 6.5mA and has over-voltage protection to 40Vdc.

Total reliability

The STT series provide a highly reliable solution for absolute tilt measurement sensing in a variety of applications. The solid state 3D-MEMS technology allows a fit-and-forget installation so that zero maintenance programs can be incorporated within vehicle or equipment service schedules.

World leading availability

The STT series have been 'designed for manufacture' enabling assembly in a state-of-the-art manufacturing cell. This means that we can supply either from stock or in a matter of days from ordering. This allows OEMs to reduce or eliminate their inventory, and call on Penny+Giles to supply 'on demand'.

Performance assured

The Penny+Giles product development process includes exhaustive qualification testing to ensure that performance specifications published in our product brochures and technical data sheets are backed by real-life test evidence. This is our assurance to you that our designs have been tested at these parameters.

STT280 SEALED TILT SENSOR



PERFORMANCE

ELECTRICAL

Measurement range	°	±10, ±20, ±30 or ±60
Supply voltage	Vdc	8 to 30 (unregulated) and 5 ±0.25 (regulated)
Over voltage protection	Vdc	Up to 40 (-40 to +90°C)
Maximum supply current	mA	<6.5
Reverse polarity protection		Yes
Short circuit protection		Yes
Output to GND		Yes
Output to supply		In 5V regulated mode only
Power-on settlement time	S	<1 to within 1% of final output
Resolution	°	±0.07
Ideal output law -		See Output Characteristics diagram on page 5
5Vdc supply	%	V output = V supply (k x sinθ + 0.5)
8 to 30Vdc supply	Vdc	V output = (5 x k x sinθ + 2.5)
		where θ is angle of inclination and k = 0.4619 for ±60° sensor k = 0.8000 for ±30° sensor k = 1.1695 for ±20° sensor k = 2.3035 for ±10° sensor
Nominal span over measurement range		80% of V supply for 5Vdc operation; 4Vdc span for 8-30Vdc operation
Maximum deviation from ideal output law	%	< ±1% of span
Zero temperature coefficient (θ=0°)	°/°C	<0.01
Sensitivity temperature coefficient		<0.015% of measured angle/°C
Output load	Ω	10k minimum (resistive to GND)
Output noise	mVrms	<1
Frequency response	Hz	1.5 (-3dB) nominal
Settling time	mS	<500 to within 1% of final output
Hysteresis and repeatability	°	±0.07
Cross-axis sensitivity†	%	<4 of normal axis sensitivity

† Cross-axis sensitivity determines how much inclination perpendicular to the measuring axis couples to the output.

MECHANICAL

Weight	g	26
Mounting		Use 2 x M4 socket head cap screws and M4 washer (not supplied) - maximum tightening torque 2Nm
Phasing		0° when cable exit is vertically down. See Dimensions, page 5, for output direction

ENVIRONMENTAL

Protection class		IP68 to 2m (for 24 hours duration)
Operational temperature†	°C	-40 to +125 (5V supply) -40 to +123 (8V supply) Derate upper temperature limit by 0.5°C for every 1V increase in supply: e.g. -40 to +112 @ 30V supply.
Storage temperature	°C	-55 to +125
Vibration		BS EN 60068-2-64: 1995 Sec 8.4 (14gn rms) 20Hz to 2000Hz Random
Shock		3m drop onto concrete (absolute maximum 20,000g)
Electromagnetic interference		BS EN 61000-4-3: 1999, to 100V/m, 80 MHz to 1GHz and 1.4GHz to 2.7GHz (2004/108/EC)

† If the maximum operating temperature is exceeded, the voltage regulator will shut down to protect the device from overheating. Data based on max supply current.

OUTPUT CHARACTERISTICS

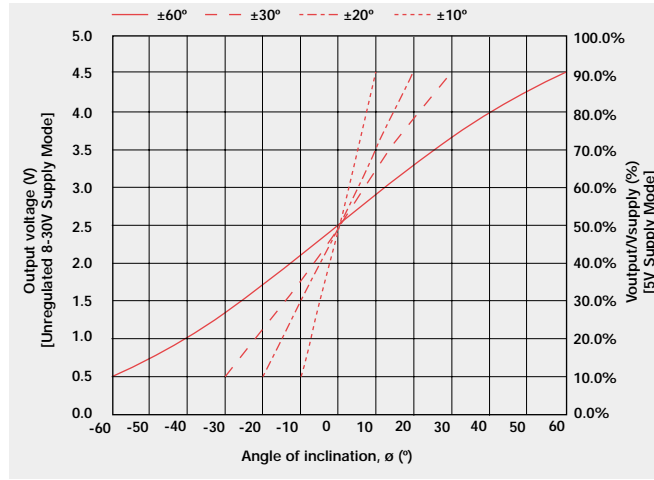

OPTIONS

Measurement range
Cable length

m

Select from $\pm 10^\circ$, $\pm 20^\circ$, $\pm 30^\circ$ or $\pm 60^\circ$. See Ordering Codes
0.2, 0.5 or 2

AVAILABILITY

All standard configurations can be supplied rapidly from the factory - check with your local supplier for more details

ORDERING CODES

Measurement range 60 = $\pm 60^\circ$
30 = $\pm 30^\circ$
20 = $\pm 20^\circ$
10 = $\pm 10^\circ$

Cable code P2 = 0.2m
P5 = 0.5m
O2 = 2.0m

STT280/ ... / ...

DIMENSIONS

Note: drawings not to scale

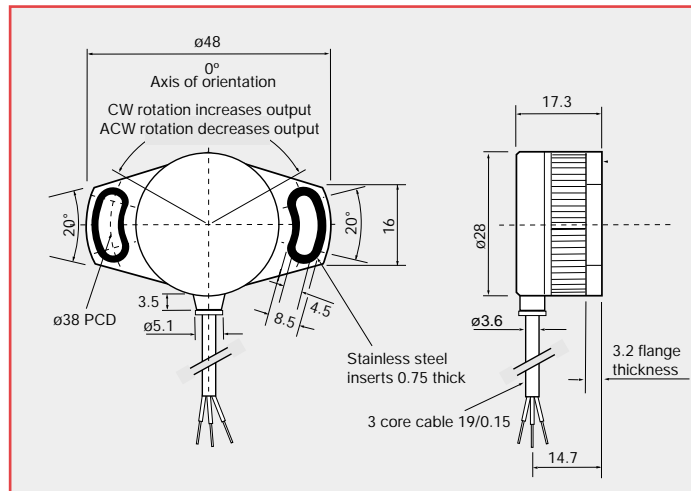

ELECTRICAL CONNECTIONS

0.2, 0.5 or 2m of 3 core cable:
PUR sheathed, with PTFE insulated
19/0.15 cores

Cable colour	Description
Red	+V Supply
Yellow	Output
Black	0V Supply (GND)

Output increases with CW rotation viewed on label

When connecting the sensor, care should be taken with the correct connections. The sensor is provided with indefinite reverse polarity protection and short circuit protection between output (Yellow) to GND (Black), but if the output (Yellow) is connected to the supply it will result in device failure.

STT500 SEALED TILT SENSOR

PERFORMANCE

ELECTRICAL

Measurement range	°	±10, ±20, ±30 or ±60
Supply voltage	Vdc	8 to 30 (unregulated) and 5 ±0.25 (regulated)
Over voltage protection	Vdc	Up to 40 (-40 to +90°C)
Maximum supply current	mA	<6.5
Reverse polarity protection		Yes
Short circuit protection		
Output to GND		Yes
Output to supply		In 5V regulated mode only
Power-on settlement time	S	<1 to within 1% of final output
Resolution	°	±0.07
Ideal output law -		See Output Characteristics diagram on page 7
5Vdc supply	%	V output = V supply (k x sinθ + 0.5)
8 to 30Vdc supply	Vdc	Voutput = (5 x k x sinθ + 2.5)
		where θ is angle of inclination and k = 0.4619 for ±60° sensor k = 0.8000 for ±30° sensor k = 1.1695 for ±20° sensor k = 2.3035 for ±10° sensor
Nominal span over measurement range		80% of Vsupply for 5Vdc operation; 4Vdc span for 8-30Vdc operation
Maximum deviation from ideal output law	%	<±1% of span
Zero temperature coefficient (θ=0°)	°/°C	<0.01
Sensitivity temperature coefficient		<0.015% of measured angle/°C
Output load	Ω	10k minimum (resistive to GND)
Output noise	mVrms	<1
Frequency response	Hz	1.5 (-3dB) nominal
Settling time	mS	<500 to within 1% of final output
Hysteresis and repeatability	°	±0.07
Cross-axis sensitivity†	%	<4 of normal axis sensitivity

† Cross-axis sensitivity determines how much inclination perpendicular to the measuring axis couples to the output.

MECHANICAL

Weight	g	200 (without cable)
Mounting		Use 3 x M6 (or 1/4UNC) socket head cap screws and suitable washer – maximum tightening torque 5-6Nm. Screws are not supplied with the sensor See Dimensions, page 7, for recommended hole positions
Phasing		0° when cable exit/connector is vertically down. See Dimensions, page 7, for output direction

ENVIRONMENTAL

Protection class		IP69K with cable code Bxx IP67 with cable code C01 (IP69K when mating connectors – see page 8 – are attached and fully engaged)
Operational temperature†	°C	-40 to +125 (5V supply) -40 to +123 (8V supply) Derate upper temperature limit by 0.5°C for every 1V increase in supply: e.g. -40 to +112 @ 30V supply.
Storage temperature	°C	-55 to +125
Vibration		BS EN 60068-2-64: 1995 Sec 8.4 (14gn rms) 20Hz to 2000Hz Random
Shock		3m drop onto concrete (absolute maximum 20,000g)
Electromagnetic interference		BS EN 61000-4-3: 1999, to 100V/m, 80 MHz to 1GHz and 1.4GHz to 2.7GHz (2004/108/EC)
Salt spray		BS EN 60068-2-52: 1996, Test Kb Severity 2 (48 Hrs)
Humidity		BS EN 60068-2-30: 2005, Severity Db (55°C, 93%RH)

† If the maximum operating temperature is exceeded, the voltage regulator will shut down to protect the device from overheating. Data based on max supply current.



OUTPUT CHARACTERISTICS

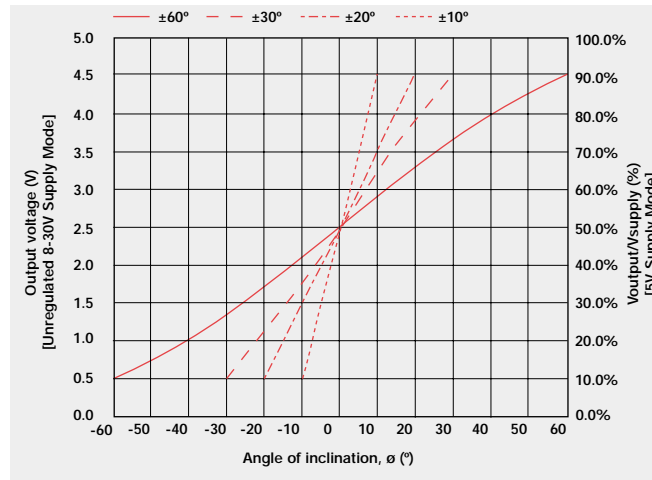

OPTIONS

Measurement range

Select from $\pm 10^\circ$, $\pm 20^\circ$, $\pm 30^\circ$ or $\pm 60^\circ$. See Ordering Codes

Electrical connections

No cable(A00), 1m, 5m or 10m unscreened cable (Bxx) or M12 receptacle (C01)

Cabled sockets

1.5, 2, 5 & 10m mating cabled sockets can be ordered separately. See details on page 8

AVAILABILITY

All standard configurations can be supplied rapidly from the factory - check with your local supplier for more details

ORDERING CODES

For no cable option A00. Extra cable can be ordered separately from 1m to 10m length in 1m increments. SA206419/MK

Length
(1m increments)

STT500/ /

Measurement range 60 = $\pm 60^\circ$
30 = $\pm 30^\circ$
20 = $\pm 20^\circ$
10 = $\pm 10^\circ$

Cable code A00 = No cable, gland fitting
B01 = 1m 3-core cable (IP69K)
B05 = 5m 3-core cable (IP69K)
B10 = 10m 3-core cable (IP69K)
C01 = M12 screw locking receptacle

DIMENSIONS

Note: drawings not to scale

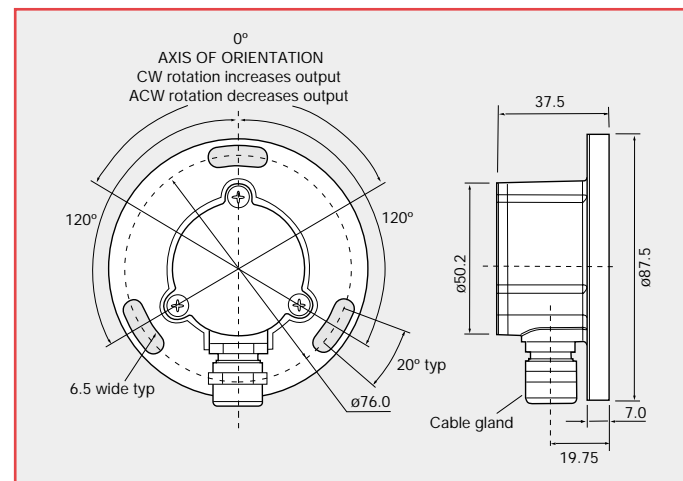

SENSOR MOUNTING DETAILS

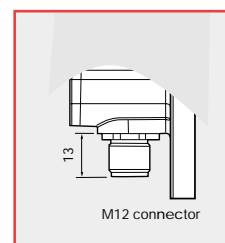
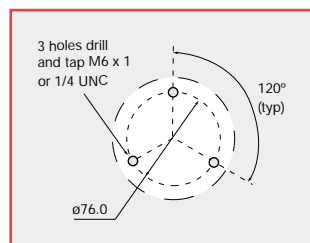

STT500 ELECTRICAL CONNECTIONS

ELECTRICAL CONNECTIONS

Option A00 – No cable supplied

Option Bxx – Cable supplied, (1m, 5m or 10m)

Option C01 – Series M12 screw locking receptacle to IEC 61076-2-101 (Ed.1) /IEC 60947-5-2 fitted to sensor body. Mating cabled sockets to be ordered separately.

CONNECTING CABLE OPTIONS

Connection details for no cable option A

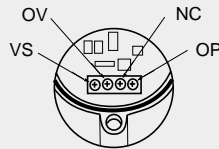

Cable gland for cable between $\phi 4$ -8mm

Connection capacity - AWG 26-16 or 0.14-1.5mm²

If cable code option A00 is selected, no cable is supplied with the sensor. It is the responsibility of the customer to make connections to the sensor connector block contained under the lid. Loosen the three captive screws, remove the lid and feed the cable through the gland to make connections. Cable diameter should be 4 to 8mm diameter. Tighten gland nut to 4.2-4.7Nm torque to ensure seal integrity. Replace lid and tighten screws to 0.7-1.2Nm torque.

Connection details for cable option Bxx

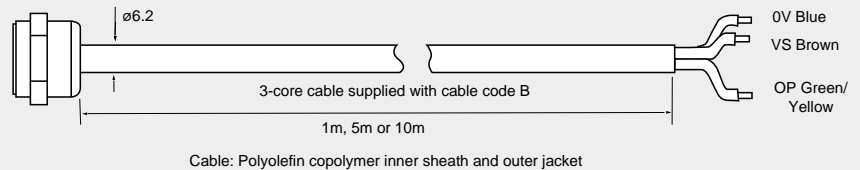

Connection details for option C01 - M12 connector

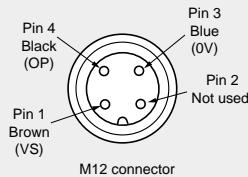

Pin No.	Cable colour	Description
1	Brown	+V Supply
2		Not connected
3	Blue	0V Supply (GND)
4	Black	Output

Output increases with CW rotation viewed on sensor lid

M12 mating connectors for cable option C01 (order separately)

Connector IP68

2 metre X61-169-102
5 metre X61-169-105
10 metre X61-226-002

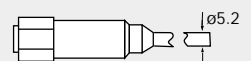
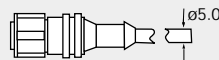

Steel connector IP69K
1.5 metre X61-222-001
5 metre X61-222-003
10 metre X61-222-005

When connecting the sensor, care should be taken with the correct connections. The sensor is provided with indefinite reverse polarity protection and short circuit protection between output to GND, **but if the outputs are connected to the supply this will result in device failure.**

STT series INSTALLATION AND APPLICATION NOTES

MOUNTING THE TILT SENSORS

STT280

See tilt sensor Dimensions on page 5.

The STT280 is designed to be mounted on a flat and smooth vertical surface by using 2 x M4 socket head cap screws and M4 washers to retain the mounting flange. The STT280 has two radial slots 4.5mm wide on a 38mm diameter PCD, with the slot length sufficient to allow $\pm 10^\circ$ offset during attachment.

The STT280 will be at approximate mid-span position when the cable outlet is vertically down. The mounting flange is fitted with stainless steel inserts around the mounting screw area to allow tightening and re-tightening without damage to the flange material. **Maximum recommended screw tightening torque is 2Nm.**

The STT280 measures the angle θ about the axis of rotation as shown in Fig.1. It is not a requirement that the sensor be mounted on the axis of rotation.

Fig.1 – Mounting orientation for STT280 and STT500 (STT280 shown)

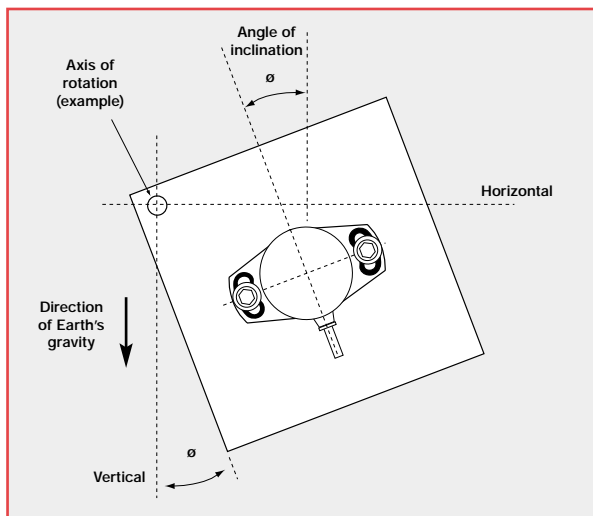

STT500

See tilt sensor Dimensions on page 7.

The STT500 is designed to be mounted on a flat and smooth vertical surface by using 3 x M6 (or 1/4 UNC) socket head cap screws and suitable washers to retain the mounting flange. The STT500 has three radial slots 6.5mm wide on a 76mm diameter PCD, with the slot length sufficient to allow $\pm 10^\circ$ offset during attachment. **Maximum recommended screw/bolt tightening torque is 5-6Nm.**

The STT500 will be at approximate mid-span position when the cable outlet (or connector) is vertically down.

The STT500 measures the angle θ about the axis of rotation. It is not a requirement that the sensor be mounted on the axis of rotation. see Fig.1 above.

APPLIED VOLTAGES

The STT280 and STT500 can operate from a 5Vdc regulated or 8–30Vdc unregulated power supply

- At **5Vdc** the sensor operates from a regulated supply in the range 4.75 to 5.25Vdc and provides a ratiometric output which is 80% of V supply over the selected full range angle of tilt, with 50% of V supply at 0° tilt. **The ratiometric output means that any change in the supply voltage will show a proportional change in the output.**
- Between **8-30Vdc** the sensor will operate from an unregulated supply in the range 8 to 30Vdc. This version has an internal voltage regulator and provides an output that is absolute and 0.5 to 4.5Vdc over the selected full range angle of tilt, with a nominal 2.5Vdc at 0° tilt. **Any variations in the supply voltage will not affect the output signal.**

The sensor circuit has a low supply current level of less than 6.5mA and has an over-voltage protection to 40Vdc.

When connecting the sensor, care should be taken when making your connections. The STT280 and STT500 are provided with indefinite reverse polarity protection and short circuit protection between output to GND, **but if the output is connected to the supply it will result in device failure.**

OUTPUT NOISE

The STT280 and STT500 both have a very low output noise level of less than 1mVrms

TILT SENSOR OUTPUT

MEMS tilt sensors are accelerometers and are linear with respect to the horizontal component of earth's gravity 'g'. When used as inclinometers or tilt sensors, they produce an output that is sine shaped and proportional to $1g \times \sin\theta$, where θ is the angle of inclination relative to the 0g position.

Ideal Output Law – see Output Characteristics graph on page 5 and 7

The output of the STT280 and STT500 follows a specific output law, depending on the supply voltage.

- **5Vdc supply**
Output (%Vs) = V supply x (k x sinθ + 0.5)
Nominal span over full range tilt is 80% of Vsupply
- **8-30Vdc supply**
Output (Vdc) = (5 x k x sinθ + 2.5)
Nominal span over full range tilt is 4Vdc
where θ is angle of inclination
and
k = 0.4619 for ±60° sensor
k = 0.8000 for ±30° sensor
k = 1.1695 for ±20° sensor
k = 2.3035 for ±10° sensor

The output can therefore be linearised by using a microcontroller (or other device) by calculating the offset required for each angle of inclination.

The STT280 and STT500 have a maximum deviation from ideal output law of $< \pm 1\%$ of span. The output is a nominal 2.5Vdc at 0° tilt. Output increases as the sensor is rotated Clockwise (viewed on label) and decreases with Anti-clockwise rotation. See Fig.2

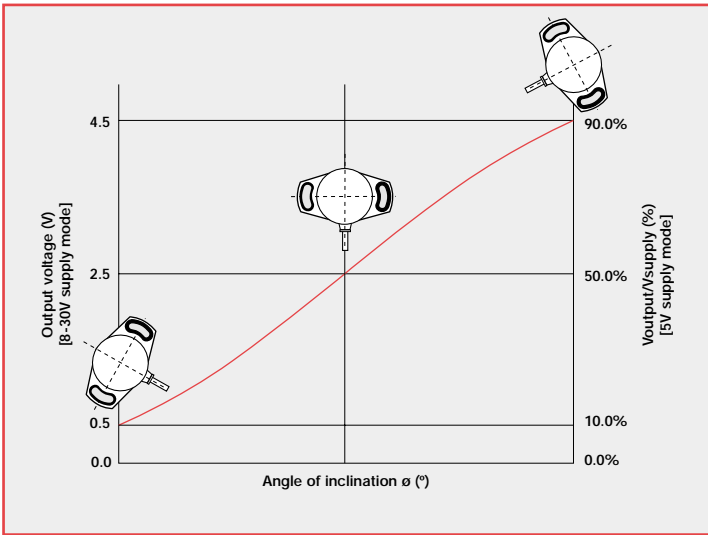

Fig. 2 – STT280 shown

CROSS-AXIS SENSITIVITY

The cross axis is the angle that the tilt sensor may be inclined away from the vertical position IN THE PLANE PERPENDICULAR TO the normal axis of rotation. The cross-axis sensitivity (< 4%) shows how much perpendicular acceleration or inclination is coupled to the STT280 or STT500 output signal. For example, if the cross axis tilt is 10°, the added error due to cross-axis sensitivity is less than $0.04 \times 10 = 0.4^\circ$. This value needs to be included when calculating output error.

ENVIRONMENTAL PERFORMANCE

STT280

The STT280 housing is manufactured using high strength corrosion resistant materials and is protected to IP68, with 2m submersion for 24 hours. It can operate in temperatures from -40 to +125°C (at 5Vdc), and has been tested to withstand a 3m drop onto concrete (maximum 20,000g). The tilt sensor also conforms to BS EN 61000-4-3, with EMC Immunity to 100V/m.

STT500

The STT500 housing is manufactured using LM6 marine grade aluminium alloy and is protected to IP69K. It can operate in temperatures from -40 to +125°C (at 5Vdc), and has been tested to withstand a 3m drop onto concrete (maximum 20,000g). The tilt sensor also conforms to BS EN 61000-4-3, with EMC Immunity to 100V/m.

By using a 3D-MEMS based sensor technology in the STT280 and STT500, this ensures a fit-and-forget installation with no moving parts that can deteriorate or wear.

LIMITATIONS OF USE

The STT280 and STT500 are designed for use in systems with a frequency response requirement of $\leq 1.5\text{Hz}$. It is not designed and cannot be used as an accelerometer unless used within the 1.5Hz maximum frequency response spectrum.



www.pennyandgiles.com

Penny & Giles

Position sensors, joysticks and solenoids for commercial and industrial applications.

15 Airfield Road
Christchurch
Dorset BH23 3TG
United Kingdom
+44 (0) 1202 409499
+44 (0) 1202 409475 Fax
sales@pennyandgiles.com

36 Nine Mile Point Industrial Estate
Cwmfelinfach
Gwent NP11 7HZ
United Kingdom
+44 (0) 1495 202000
+44 (0) 1495 202006 Fax
sales@pennyandgiles.com

665 North Baldwin Park Boulevard
City of Industry, CA 91746
USA
+1 626 480 2150
+1 626 369 6318 Fax
us.sales@pennyandgiles.com

Straussenlettenstr. 7b
85053 Ingolstadt,
Germany
+49 (0) 841 885567-0
+49 (0) 841 885567-67 Fax
info@penny-giles.de

3-1-A, Xiandai Square,
No 333 Xingpu Rd,
Suzhou Industrial Park, 215126
China
+86 512 6287 3380
+86 512 6287 3390 Fax
sales@pennyandgiles.com.cn

The information contained in this brochure on product applications should be used by customers for guidance only. Penny+Giles Controls Ltd makes no warranty or representation in respect of product fitness or suitability for any particular design application, environment, or otherwise, except as may subsequently be agreed in a contract for the sale and purchase of products. Customer's should therefore satisfy themselves of the actual performance requirements and subsequently the products suitability for any particular design application and the environment in which the product is to be used.

Continual research and development may require change to products and specification without prior notification. All trademarks acknowledged.

© Penny+Giles Controls Ltd 2012

Innovation In Motion



www.cwcontrols.com