

# Instruction Manual

## 4-20 mA Vibration Sensor Type

# KSI84xx

v1.32.034



Manfred Weber

Metra Mess- und Frequenztechnik in Radebeul e.K.

Meissner Str. 58 - D-01445 Radebeul

Tel. +49-351 836 2191 Fax +49-351 836 2940

Email: [info@MMF.de](mailto:info@MMF.de) Internet: [www.MMF.de](http://www.MMF.de)

**Revision:**

| <b>Edition</b> | <b>Firmware</b> | <b>Revision</b>   |
|----------------|-----------------|---|
| 15.11.2021     | v1.32.030       | new chapter: <a href="#">4.8 Total Accuracy</a>   |
| 20.01.2022     |                 | Change: <a href="#">4.2.2 Sensor Cable</a> ; <b>Fehler! Verweisquelle konnte nicht gefunden werden.</b> <a href="#">Grounding Concept</a> |
| 20.01.2022     | v1.32.031       | new sensor types with 5 m/s <sup>2</sup> range  |
|                |                 | Increase of <a href="#">maximum dynamic range</a> for types KSI84Ax with LP ≤ 1 kHz: see chapter 4.5.5                                    |
| 13.05.2022     | v1.32.033       | Order option: <a href="#">Current output limited to 20 mA</a>   |
|                |                 | Change of <a href="#">update rate for PEAK measurement</a> : 0.5 s  |
|                |                 | New sensor types <a href="#">KSI84D-3-300-xx</a> for displacement measurement   |
| 13.06.2022     | v1.32.034       | <a href="#">Update rate</a> at types KSI84AR-1k-10k-xxx: 62,5 ms  |

**Published by:**

Manfred Weber  
Metra Mess- und Frequenztechnik in Radebeul e.K.  
Meißner Str. 58  
D-01445 Radebeul

Tel. 0351-836 2191  
Fax 0351-836 2940  
Email [Info@MMF.de](mailto:Info@MMF.de)  
Internet [www.MMF.de](http://www.MMF.de)

Note: The latest version of this document can be found at:  
[https://www.mmf.de/product\\_literature.htm](https://www.mmf.de/product_literature.htm)

All rights reserved, including those of translation.  
Subject to modifications.  
© 2021 Manfred Weber Metra Mess- und Frequenztechnik in Radebeul e.K.

**Edition:** 28.09.2022

# Contents

|   |           |
|---|-----------|
| <b>1 Purpose</b> .....                                      | <b>4</b>  |
| <b>2 Function</b> .....                                     | <b>4</b>  |
| <b>3 Type Selection</b> .....                               | <b>5</b>  |
| 3.1 Frequency Range (HP, LP).....                           | 5         |
| 3.2 Measuring Range.....                                    | 6         |
| 3.3 Type Code .....   | 7         |
| <b>4 Sensor Operation</b> .....                             | <b>7</b>  |
| 4.1 Sensor Mounting.....                                    | 7         |
| 4.2 Sensor Connection .....                                 | 8         |
| 4.2.1 Connection to the Loop Supply .....                   | 8         |
| 4.2.2 Sensor Cable .....                                    | 8         |
| 4.2.3 Grounding Concept.....                                | 8         |
| 4.3 Measuring the sensor current .....                      | 9         |
| 4.3.1 Maximum Load Resistance $R_L$ .....                   | 10        |
| 4.4 Sensor Self-Test .....                                  | 10        |
| 4.5 Measuring Mode .....                                    | 10        |
| 4.5.1 Sensitivity $B_i$ .....                               | 10        |
| 4.5.2 Calculation of measured quantity .....                | 11        |
| 4.5.3 Offset Current and <i>Noise</i> .....                 | 11        |
| 4.5.4 Linear Measuring Range $X_{min}...X_{max}$ .....      | 12        |
| 4.5.5 Dynamic Range .....                                   | 12        |
| 4.6 Overload Display.....                                   | 13        |
| 4.7 Measurement Acquisition.....                            | 13        |
| 4.7.1 Averages Filter - Settling Time.....                  | 13        |
| 4.8 Total Accuracy .....                                    | 14        |
| 4.9 Error Messages.....                                     | 15        |
| 4.9.1 Steps to Fix a LOOP Error .....                       | 15        |
| <b>5 Technical Data</b> .....                               | <b>16</b> |
| 5.1 Technical Characteristics of the 4-20mA transducer..... | 16        |
| 5.2 Electrical Characteristics.....                         | 16        |
| 5.3 Mechanical Characteristics .....                        | 16        |
| 5.4 Environmental Characteristics .....                     | 17        |
| 5.5 Type Tables .....                                       | 17        |
| 5.5.1 Acceleration, RMS .....                               | 17        |
| 5.5.2 Acceleration, PEAK.....                               | 18        |
| 5.5.3 Velocity, RMS .....                                   | 18        |
| 5.5.4 Velocity, PEAK.....                                   | 19        |
| 5.5.5 Displacement .....                                    | 19        |
| 5.6 Dimensions .....  | 20        |
| <b>Limited Warranty</b> .....                               | <b>21</b> |
| <b>Declaration of Conformity</b> .....                      | <b>21</b> |

# 1 Purpose

The vibration sensors of the KSI84xx family are used to measure vibration acceleration, velocity or displacement on machines and objects.

The sensors measure the vibration amplitude within a specified frequency range in axial sensor direction and outputs the measuring result as a 4-20 mA current loop signal. The sensor is supplied with power via the same signal line.

The sensor parameters are adjustable. There are different types for different applications in several measuring ranges. The sensors comply with the specifications for vibration measuring devices according to [ISO 2954](#).

Possible applications are:

1. Measurement of the smooth running of rotating machines and reciprocating machines according to [ISO 10816](#) / [ISO 20816](#).
2. Measurement of bearing vibrations according to [VDI 3832](#).
3. Measurement of vibrations in defined frequency ranges.

The sensors are suitable for use in harsh environmental conditions. The housing is double shielded, electrically isolated and complies with protection grade IP68.

# 2 Function

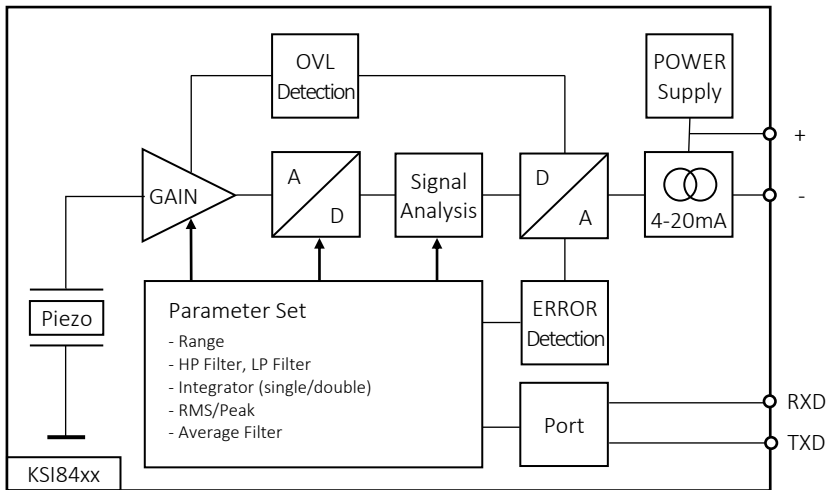

The sensors of the KSI84xx family are piezoelectric vibration sensors.

A piezoelectric accelerometer is used as the sensor element. Its electrical output signal is first amplified and digitized.

The signal analysis is digital. The signal is filtered (HP, LP), optionally integrated and the amplitude value is calculated, either as RMS or PEAK value. Finally, the amplitude value is converted into a 4-20 mA current loop signal with a 16 bit DAC.

Either the acceleration (without integrator), the velocity (integrator) or the displacement (double integrator) of the vibration can be measured.

In addition, proper sensor function and input signal are monitored. Defects or overloads are signaled by an [error current value](#).

Before delivery, the sensor is parameterized according to the [type code](#) selected by the customer.

### 3 Type Selection

There are five different basic types, which differ in the measured quantity (Q) and the amplitude mode (M).

| Sensor type | KS184AR | KS184AP | KS184VR      | KS184VP | KS184D   |              |
|-------------|---------|---------|--------------|---------|----------|--------------|
| Quantity    | Q       |         | Acceleration |         | Velocity | Displacement |
| Mode        | M       | RMS     | PEAK         | RMS     | PEAK     | PEAK-PEAK    |

Furthermore, the types differ in the measured frequency range (HP, LP) and in their measuring range.

#### 3.1 Frequency Range (HP, LP)

The used frequency range of a sensor type is described by the values HP and LP in the [type table](#).

**HP** is the -3 dB cutoff frequency of the high pass filter and determines the lower cutoff frequency of the sensor.

**LP** is the -3 dB cutoff frequency of the low pass filter and determines the upper cutoff frequency of the sensor.

All frequencies between the lower and upper cutoff frequency have an impact to the measuring result.

Sensors measuring **acceleration** have a 2nd order IIR high pass and low pass filter with a stopband attenuation of -40 dB/decade.

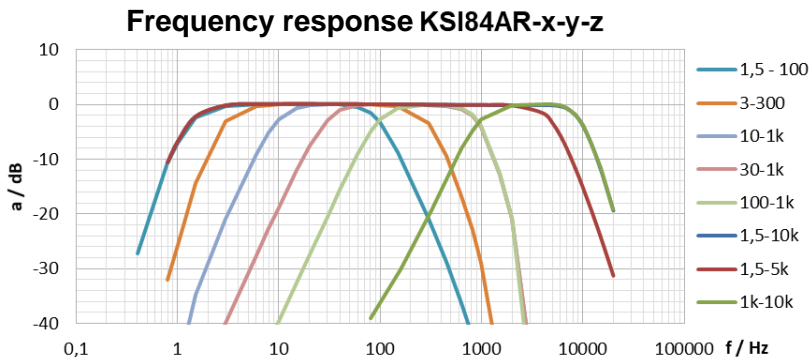

The HP filter of the **velocity** sensor types has a stopband attenuation of -50 dB/decade, the LP filter has a stopband attenuation of - 40 dB/decade.

### Frequency response KSI84VR-x-y-z

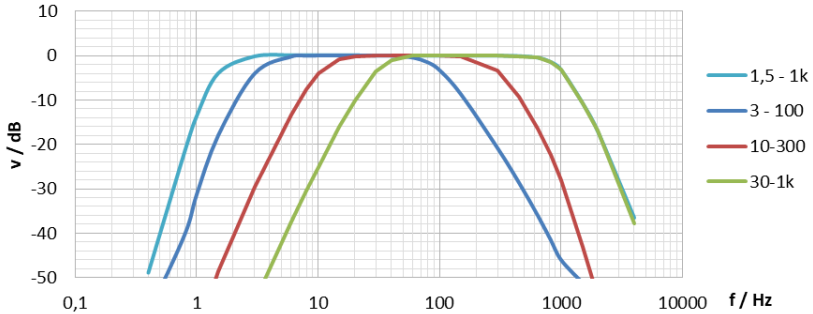

The HP filter of the **displacement** sensor types has a stopband attenuation of -60 dB/decade. The upper cut-off frequency is 300 Hz. It results from the significant decrease of the [dynamic range](#) with increasing frequency. At 300 Hz the maximum current amplitude is only 1 % of the [measuring range](#).

### Frequency response KSI84D-3-300-x

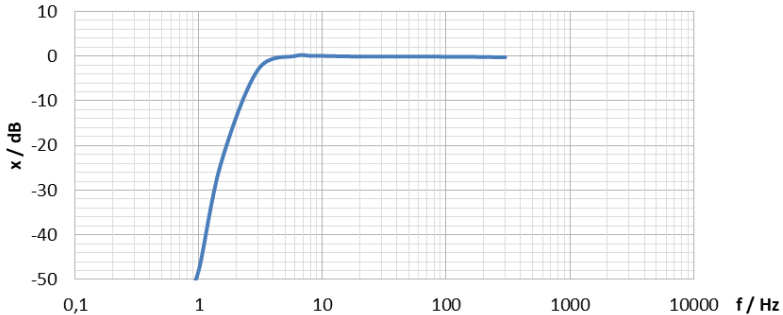

## 3.2 Measuring Range

The “Range” value specified in the [type table](#) corresponds to the value of the measured quantity at which the sensor current is 20 mA. At this value, the sensor output is set to 100 %.

The measurement result should always be within the [linear measuring range](#) of the sensor. It ranges from 4.16 mA (1 %) to 22 mA (112.5 %).

If 22 mA cannot be processed by the used measuring instrument, the output current can optionally be limited to 20 mA (specify when ordering if necessary).

### 3.3 Type Code

The type code is printed on the sensor housing. It is composed according to the following key. Note that only integer values without decimal places are printed in the type code.

KSI84**QM**-**HHH**-**LLL**-**RRR**

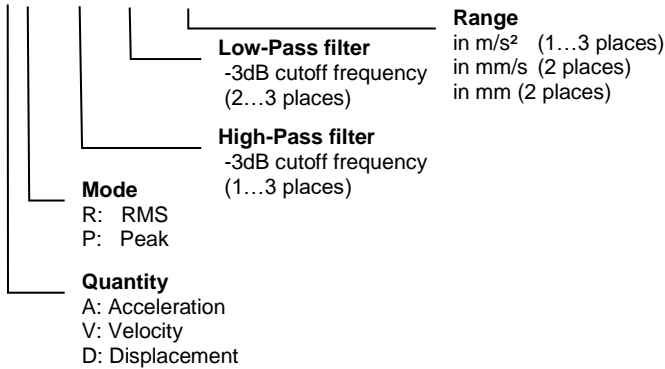

## 4 Sensor Operation

### 4.1 Sensor Mounting

The choice of an appropriate measuring point on the target is important for accurate vibration measurement. It can be helpful to consult a specialist in machine monitoring for this purpose.

In general, it is advisable to measure vibrations as near as possible to their source. This minimizes errors by transmitting mechanical components.

Suitable measuring points are rigid components, for instance the housing of bearings or gearboxes. Not recommended for vibration measurement are lightweight, flexible and soft components. The standard ISO 10816-1 gives some recommendations for suitable measuring points.

The KSI84xx is mounted via the M8 threaded hole in the sensor base. The sensor can either be mounted directly using the M8 mounting stud [type 043](#) or with the help of the mounting pad [type 229](#) with M8 stud by epoxy cementing on the object.

Alternatively, the sensor can also be fixed by the magnetic base [type 208](#) (M8) or [type 008](#) (M5) in combination with the thread adapter [type 044](#).

The sensor should be in touch with the target by its complete mounting surface. Rough, scratched or too small measuring points may cause errors. Cast or varnish surfaces are unsuited.

A thin layer of silicone grease between the mounting surfaces also improves vibration transmission.

## 4.2 Sensor Connection

### 4.2.1 Connection to the Loop Supply

The sensor is connected via PIN 2 (+) and PIN 3 (-) of the output connector to the loop supply voltage. PIN 1 and PIN 4 are not to be connected.

#### View at sensor pins

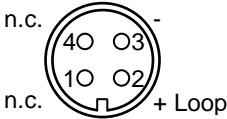

- 1: Do not connect
- 2: + current loop
- 3: - current loop
- 4: Do not connect

The loop supply voltage  $U_S$  should be within 10 to 30 V and free of noise.

It is recommended to select a lower voltage at ambient temperatures above 80 °C in order to reduce self-heating due to the power dissipation inside the sensor.

### 4.2.2 Sensor Cable

We recommend to use a two-core shielded cable for best EMI protection.

Alternatively, the sensor can also be connected with a four-core, shielded cable with a moulded plug. The unused wires must remain open.

Metra offers the following connection accessory:

- [Type 080G/W](#): Binder 713, female, straight (G) or angled (W) with screw terminals for connection an existing sensor cable; protection grade IP67
- [Type 082-B713G-PIG-x](#) or [type 082-B713G-PIG-x](#): Shielded sensor cable, x m length with Binder 713, female, straight (G) or angled (W) and cable end sleeves; protection grade IP67

Make sure that the cable is not routed alongside AC power lines and in adequate distance to potential EMI sources. It should cross AC power lines at right angles.

### 4.2.3 Grounding Concept

The sensor has an outer and an inner housing shield to protect the electronics against EMI. Both housings are electrically isolated from each other.

The inner housing is connected to the potential of the negative loop line via PIN3. The outer sensor housing is either connected directly to the device potential at the mounting location via the M8 thread (case 1) or obtains its reference potential via the cable shield (case 2).



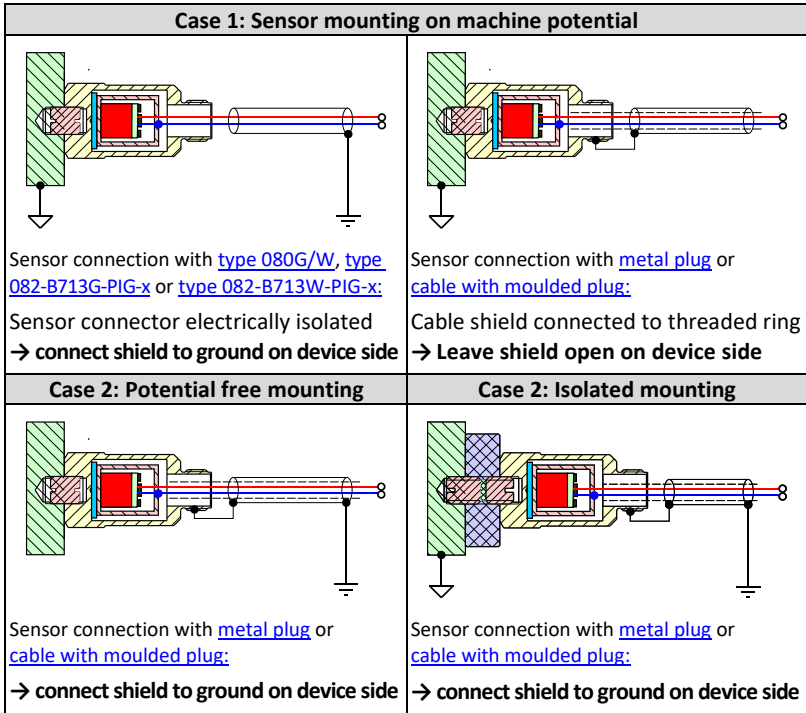

### 4.3 Measuring the sensor current

The following figures show possibilities to measure the sensor current.

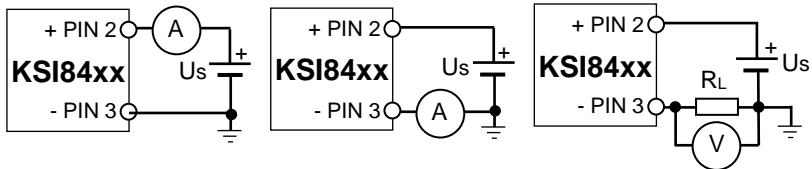

The sensor current can be measured either directly by a current meter connected in series or indirectly by measuring the voltage drop across the load resistance  $R_L$  between PIN 3 and the negative terminal.

Choose the connection shown in the first figure for best **EMI** protection.

The voltage drop  $u_L$  across  $R_L$  is calculated from the sensor current as follows:

$$u_L = R_L \cdot i_{sensor}$$

The following table shows the voltage drop  $u_L$  as a function of the sensor current at different load resistors  $R_L$ .

| Excitation | $i_{Sensor}$ | Voltage drop over $R_L$ |              |              |
|------------|--------------|-------------------------|--------------|--------------|
|            |              | 125 $\Omega$            | 250 $\Omega$ | 500 $\Omega$ |
| 0 %        | 4 mA         | 0,5 V                   | 1 V          | 2 V          |
| 10 %       | 5,6 mA       | 0,7 V                   | 1,4 V        | 2,8 V        |
| 20 %       | 7,2 mA       | 0,9 V                   | 1,8 V        | 3,6 V        |
| 50 %       | 12,0 mA      | 1,5 V                   | 3 V          | 6 V          |
| 100 %      | 20,0 mA      | 2,5 V                   | 5 V          | 10 V         |
| 112,5 %    | 22,0 mA      | 2,75 V                  | 5,5 V        | 11 V         |

### 4.3.1 Maximum Load Resistance $R_L$

The maximum load resistance  $R_L$  depends on the loop supply voltage  $U_S$ . It results from the fact that the sensor requires at least 7 V at the highest possible loop current.

The calculation is as follows:

$$R_L \leq \frac{U_S - 7 \text{ V}}{24 \text{ mA}} \approx 40 \cdot (U_S - 7) \cdot \text{ohm}$$

$R_L$  : Load resistance of current loop  
 $U_S$ : Loop supply voltage in V

It can be seen that the load resistance  $R_L$  must not exceed 680  $\Omega$  with a supply voltage  $U_S = 24 \text{ V}$ .

## 4.4 Sensor Self-Test

The sensor starts with a self-test once it is connected to the loop supply voltage.

During self-test, the sensor outputs the maximum sensor current (22 mA<sup>1)</sup>) and the [offset current](#) of 4 mA for a duration of 2 seconds. These currents can be measured with an ampere meter to ensure proper function.

If there is no error, the normal measuring operation starts afterwards, in which the sensor current corresponds to the current measured value.

There is a [LOOP error](#) if the sensor is not able to drive 22 mA<sup>1)</sup>. In this case, the sensor repeats the self-test until the error is fixed.

## 4.5 Measuring Mode

### 4.5.1 Sensitivity $B_i$

In measuring mode, the sensor output current  $i_{Sensor}$  is proportional to the vibration amplitude of the measured quantity  $x$ . A constant [offset current](#) of 4 mA is overlaid on this current for the sensor supply.

$$i_{Sensor} = B_i \cdot a + 4 \text{ mA}$$

The proportionality factor  $B_i$  is called sensitivity. The sensitivity depends on the measuring range of the sensor. It results from the quotient of the current change at 100 % excitation and the measuring range.

<sup>1)</sup> 20 mA for order option with [limited output current](#)

$$B_i = \frac{(20 \text{ mA} - 4 \text{ mA})}{\text{Range}} = \frac{16 \text{ mA}}{\text{Range}}$$

The following table shows the sensitivity of the acceleration and velocity types for different measuring ranges.

|                            | Range in m/s <sup>2</sup> |           |           |           |            |            |            |
|----------------------------|---------------------------|-----------|-----------|-----------|------------|------------|------------|
| <b>KSI84Ax</b>             | <b>5</b>                  | <b>10</b> | <b>20</b> | <b>50</b> | <b>100</b> | <b>200</b> | <b>500</b> |
| $B_{iv} / \text{mA/m/s}^2$ | 3,2                       | 1,6       | 0,8       | 0,32      | 0,16       | 0,08       | 0,032      |

|                           | Range in mm/s |             |           |             |           |             |  |
|---------------------------|---------------|-------------|-----------|-------------|-----------|-------------|--|
| <b>KSI84Vx</b>            | <b>10</b>     | <b>12.7</b> | <b>20</b> | <b>25.4</b> | <b>40</b> | <b>50.8</b> |  |
| $B_{iv} / \text{mA/mm/s}$ | 1.6           | 1.26        | 0.8       | 0.63        | 0.4       | 0.315       |  |

|                         | Range in mm |             |           |             |           |             |  |
|-------------------------|-------------|-------------|-----------|-------------|-----------|-------------|--|
| <b>KSI84D</b>           | <b>10</b>   | <b>12.7</b> | <b>20</b> | <b>25.4</b> | <b>40</b> | <b>50.8</b> |  |
| $B_{id} / \text{mA/mm}$ | 1.6         | 1.26        | 0.8       | 0.63        | 0.4       | 0.315       |  |

The sensitivity  $B_i$  changes only slightly over temperature due an electronic compensation. The remaining TC( $B_i$ ) can be found in the [technical data](#).

#### 4.5.2 Calculation of measured quantity

The amplitude of the measured quantity (a, v or d) is determined from the sensor current as follows:

$$a, v, d = \frac{1}{B_i} \cdot (i_{\text{Sensor}} - 4 \text{ mA}) = \frac{\text{Range}}{16 \text{ mA}} \cdot (i_{\text{Sensor}} - 4 \text{ mA})$$

#### 4.5.3 Offset Current and Noise

The offset current  $I_{\text{off}}$  of the sensor is **4 mA**. This is the **zero point** in measuring mode. The calibrated value is output while [sensor elf-test](#) for control.

A slightly larger current value is measured when no vibration excitation is present, the current in rest. This is the smallest output value in measuring mode. It consists of the offset current and the current of the sensor noise.

$$I(0) = 4 \text{ mA} + I_{\text{Noise}}$$

The *Noise* depends on the type and is specified in the [type table](#) in m/s<sup>2</sup> or mm/s. Multiplication by the [sensitivity](#)  $B_i$  gives:

$$I_{\text{Noise}} = \text{Noise} \cdot \frac{16 \text{ mA}}{\text{Range}}$$

The offset current  $I_{\text{off}}$  changes only slightly over temperature and time. For details see in [technical data](#).

#### 4.5.4 Linear Measuring Range $x_{min}...x_{max}$

The current loop sensor is calibrated at two vibration amplitudes to achieve optimum linearity of the sensor current over the entire measuring range.

The range for valid measurements extends from ...

|     | $x_{min}$              | $x_{max}$                                 | Sensor types                          |
|-----|------------------------|---|---------------------------------------|
| (1) | 1 % of range (4.16 mA) | 112.5 % of range<br>(22 mA) <sup>1)</sup> | All types except (2)                  |
| (2) | 2 % of range (4.32 mA) |   | KSI84AP-xx-10k-xxx<br>KSI84AR-xx-xx-5 |

Within this measuring range, the linearity of sensitivity (gain error) specified in the [technical data](#) is maintained.

If the vibration signal is **smaller** than the specified minimum  $x_{min}$ , the measurement error increases due to sensor noise and the limited resolution of the AD converter.

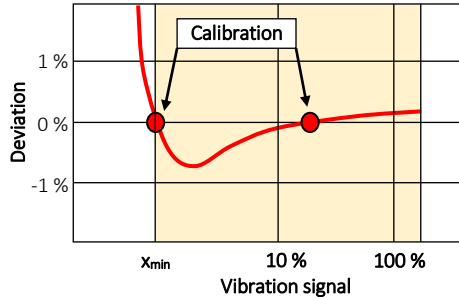

At vibration amplitudes **greater**

than the maximum  $x_{max}$ , the sensor current no longer increases. It remains constant at **22 mA**<sup>1)</sup>. A sensor with a larger measuring range must be selected.

#### 4.5.5 Dynamic Range

The dynamic range is the maximum peak amplitude value that can be processed without overdriving the signal processing. It is shown in the following table for the acceleration or velocity signal and the different measuring ranges.

The following table contains the maximum acceptable peak value of the acceleration, velocity or displacement signal for the different ranges.

|                         |            | Range in m/s <sup>2</sup> |           |           |           |            |            |            |
|-------------------------|------------|---------------------------|-----------|-----------|-----------|------------|------------|------------|
| <b>KSI84Ax</b>          |            | <b>5</b>                  | <b>10</b> | <b>20</b> | <b>50</b> | <b>100</b> | <b>200</b> | <b>500</b> |
| a_pk / m/s <sup>2</sup> | LP ≤ 1 kHz | 47                        | 47        | 95        | 195       | 390        | 780        | 780        |
| a_pk / m/s <sup>2</sup> | LP ≥ 5 kHz | -                         | 47        | 47        | 95        | 195        | 390        | 780        |

|                |         | Range n mm/s |             |           |             |           |             |
|----------------|---------|--------------|-------------|-----------|-------------|-----------|-------------|
| <b>KSI84Vx</b> |         | <b>10</b>    | <b>12,7</b> | <b>20</b> | <b>25,4</b> | <b>40</b> | <b>50,8</b> |
| v_pk / mm/s    | @160 Hz | 95           | 95          | 190       | 190         | 380       | 380         |
| v_pk / mm/s    | @640 Hz | 24           | 24          | 48        | 48          | 95        | 95          |

|               |         | Range in mm |             |           |             |           |             |
|---------------|---------|-------------|-------------|-----------|-------------|-----------|-------------|
| <b>KSI84D</b> |         | <b>10</b>   | <b>12,7</b> | <b>20</b> | <b>25,4</b> | <b>40</b> | <b>50,8</b> |
| x_pk-pk / mm  | @16 Hz  | 40          | 50,8        | 80        | 101         | 160       | 203         |
| x_pk-pk / mm  | @32 Hz  | 10          | 12,7        | 20        | 25,4        | 40        | 50,8        |
| x_pk-pk / mm  | @160 Hz | 0,4         | 0,5         | 0,8       | 1,1         | 1,6       | 2,03        |

<sup>1)</sup> optional 20 mA (100 %) available

For **accelerometers**, the dynamic range is independent of frequency. The sensor setting LP of the low-pass filter defines the corresponding range of values.

For all **velocity** sensors, the dynamic range depends on the frequency. It is halved when the frequency doubles.

The dynamic range of the displacement sensors depends strongly on the frequency. 100 % of measuring range can only be used at frequencies  $f \leq 32$  Hz. At higher frequencies, the measuring range is limited. It decreases by a factor  $\frac{1}{4}$  with each doubling of the frequency.

## 4.6 Overload Display

To signal an existing overload, the sensor outputs the maximum output current of 22 mA<sup>1)</sup>. The overload does not necessarily have to be in the linear frequency range of the sensor. It can also be within the stopband of the sensor type.

If there is an overload, the measurement result is incorrect and a sensor with a larger measuring range must be used.

## 4.7 Measurement Acquisition

The current output of the sensor is updated every 0.5 seconds. The only exceptions are the types KSI84AR-1k-10k-xx, where the update rate is 62.5 ms.

The RMS measurement is based on all samples within this time window.

The PEAK measurement uses the samples from two consecutive time windows. This results in a PEAK hold time of 1s.

### 4.7.1 Averages Filter - Settling Time

To reduce signal ripple by low frequencies and to improve the signal-to-noise ratio, the output signal is additionally filtered using a moving average filter. The number of averages  $N$  is adjustable.

By **default**, the sensor is delivered with the average filter setting  $N = \text{auto}$ . In this mode the number of averages  $N$  depends on the amplitude mode (rms, peak) and on the high pass filter setting.

| HP-Filter             | average filter= auto |       |
|-----------------------|----------------------|-------|
|                       | RMS                  | PEAK  |
| 1.5 Hz / 3 Hz / 10 Hz | N = 8                | N = 8 |
| 30 Hz / 100 Hz        | N = 4                |       |
| 1 kHz                 | N = 1                |       |

**Optionally**, the averaging filter can also be obtained with the settings  $N = 1, 2, 4, 8$ . The setting of the average filter can also be adjusted afterwards.

<sup>1)</sup> 20 mA for order option with [limited output current](#)

The averaging filter causes a signal delay. If the vibration signal changes abruptly, the sensor signal only changes smoothly. The signal change is not completed until the settling time  $T$  has elapsed.

The table below shows the relationship between the number of averages  $N$  and the minimal settling time  $T$ .

| N | PEAK      | RMS, HP < 1 kHz | RMS, HP = 1 kHz |
|---|-----------|-----------------|-----------------|
| 1 | T = 0,5 s |                 | T = 62,5 ms     |
| 2 | T = 1 s   |                 | T = 125 ms      |
| 4 | T = 2 s   |                 | T = 250 ms      |
| 8 | T = 4 s   |                 | T = 0,5 s       |

We recommend to use a short settling time for the use of the sensor in a closed control loop. Please specify when ordering: N=1 or N=2.

## 4.8 Total Accuracy

All vibration sensors of the KSI84xx family are individually measured and calibrated before delivery. Calibration is performed both electrically and mechanically in our certified [vibration measurement laboratory](#).

Systematic errors caused by temperature are largely corrected by signal processing.

The following overview contains the most important error quantities to estimate the total accuracy of the sensor.

| Error quantities                                 | Max                     | Importance   |
|--|-------------------------|--|
| Basic accuracy of the nominal range              | 2 %                     | Accuracy of the sensor sine calibration (at a certain amplitude and frequency, at $T = 23\text{ °C}$ )   |
| Linearity  | 2 %                     | Additional error at any amplitude. The typical error function is shown in chapter 4.5.4. The error maximum is at the lower end of the <a href="#">linear measuring range</a> . |
| Temperature                                      | $E_T$ %                 | Additional error at any temperature within the operating temperature range.<br>$E_T(T) = TC(B_i) \cdot (T - 23\text{ °C})$   |
| <a href="#">Frequency response</a>               | 1 %                     | Additional error due to deviation of sensor frequency response from ideal frequency response   |
| Basic accuracy of <a href="#">offset current</a> | 1 $\mu\text{A}$         | These errors influence the zero point of the sensor. They effect to the total error only at very low vibration levels.   |
| Offset current drift                             | <a href="#">see 5.1</a> |  |
| <a href="#">Noise</a>                            | <a href="#">see 5.5</a> |  |

## 4.9 Error Messages

If the sensor current is between 4 mA and 22 mA<sup>1)</sup>, the sensor is in normal operational mode.

Any current outside this range indicates a specific error. The following table shows the values used.

| Current            | Error                          | Cause  | Remedy  |
|--------------------|--------------------------------|--|---|
| 3,75 mA            | LOOP Error                     | The sensor cannot output the correct current value because the current loop proper setup | Restart the sensor.<br>There is a LOOP-Error if the sensor remains in <a href="#">self-test</a> after restart.<br>→ <b>follow steps 4.9.1</b>                     |
|                    | SENSOR Error                   | Die Signalverarbeitung des Sensors arbeitet nicht normal.                                | Restart the sensor.<br>There is a SENSOR-Error if the Sensor does not start with the self-test. The sensor constantly outputs 3,75 mA.<br>→ <b>Replace sensor</b> |
| 22mA <sup>1)</sup> | <a href="#">Overload</a> (OVL) | Vibration signal too high  | Use a sensor type with a higher measuring range.<br>→ <b>Replace sensor</b>   |

### 4.9.1 Steps to Fix a LOOP Error

1. Check the value of the [load resistance R<sub>L</sub>](#) and reduce it if possible
2. Check the value of the [loop supply voltage](#) and increase it if possible

<sup>1)</sup> 20 mA for order option with [limited output current](#)

## 5 Technical Data

| 5.1 Technical Characteristics of the 4-20mA transducer  |   |   |   |
|---|---|---|---|
| Sensor system   |   | Piezoelectric accelerometer   |   |
| Measured quantity   | Q<br>KSI84A <i>x-x-x-x</i><br>KSI84V <i>x-x-x-x</i><br>KSI84D <i>x-x-x-x</i>                            | according to <a href="#">type code</a><br>Acceleration<br>Velocity<br>Displacement  | m/s <sup>2</sup><br>mm/s<br>mm <sub>pk-pk</sub> |
| Mode  | M<br>KSI84xR <i>x-x-x-x</i><br>KSI84xP <i>x-x-x-x</i>   | according to <a href="#">type code</a><br>RMS<br>PEAK   | ... pk  |
| Linear frequency range<br>High pass filter <sup>1)</sup> -3dB<br>Low pass filter <sup>2)</sup> -3dB | f <sub>HP</sub> KSI84xx- <b>HP</b> - <i>x-x</i><br>f <sub>LP</sub> KSI84xx- <b>LP</b> - <i>x</i>        | according to <a href="#">type code</a><br>1.5 / 3 / 10 / 30 / 100 / 1k<br>100 / 300 / 1k / 5k / 10k                                     | Hz<br>Hz  |
| Nominal range <sup>3)</sup> ± accuracy  | x <sub>N</sub> @20 mA, @23°C<br>KSI84A <i>x-x-x-R</i><br>KSI84V <i>x-x-x-R</i><br>KSI84D <i>x-x-x-R</i> | according to <a href="#">type code</a><br>5/10/20/50/100/200/500± 2 %<br>10/12.7/20/25.4/40/50.8 ± 2 %<br>10/12.7/20/25.4/40/50.8 ± 5 % | m/s <sup>2</sup><br>mm/s<br>mm <sub>pk-pk</sub> |
| Linear measuring range  | x <sub>min</sub> ... x <sub>max</sub>   | 1...112.5 <sup>3)</sup> ; (2...112.5) <sup>4)</sup>   | % of x <sub>N</sub>                             |
| Linearity of sensitivity<br>(Gain error)  | δB <sub>ix</sub> @x <sub>min</sub> ... x <sub>max</sub><br>@23°C  | ± 2   | %   |
| Temperature coefficient of sensitivity  | TC(B <sub>i</sub> )   | + 0.015   | %/K   |
| Max. offset drift over temp.  | ΔI <sub>off</sub> @T <sub>min</sub> ...T <sub>max</sub>   | ± 4   | µA  |
| Max. offset drift over time   | ΔI <sub>off</sub> @5.000 h  | + 1   | µA  |
| Resolution (noise)  |   | see <a href="#">type table</a>  |   |
| Transverse sensitivity  | G <sub>90max</sub>  | < 5   | %   |
| 5.2 Electrical Characteristics  |   |   |   |
| Current output  | I <sub>OUT</sub>  | 4...22 <sup>3)</sup>  | mA  |
| Loop supply voltage   | U <sub>S</sub>  | 10...30   | V   |
| Settling time <sup>5)</sup>   | T @f <sub>HP</sub> =1kHz; RMS<br>@all types   | < 0,125<br>< 5  | s<br>s  |
| Load resistance   | R <sub>L</sub>  | < 40 · ( U <sub>S</sub> - 7 )   | Ω   |
| Ground insulation   | R <sub>ISO</sub> @250 VDC   | > 4000  | MΩ  |
| Dielectric strength   | U <sub>ISO</sub>  | 350   | VDC   |
| 5.3 Mechanical Characteristics  |   |   |   |
| Dimensions  | Ø / h   | SW22 / 43.1   | mm  |
| Weight  | m   | 60 / 2.1  | g / oz  |
| Housing material  |   | Stainless steel   |   |
| Mounting  |   | M8 thread in base   |   |
| Connector   |   | Binder 713, 4 pole, male  |   |

<sup>1)</sup> Type code contains only integer values without decimal places

<sup>2)</sup> The condition LP ≥ 10 HP must be met

<sup>3)</sup> 20 mA (100 %) for order option with [limited output current](#)

<sup>4)</sup> Restricted linear measuring range for [type code](#) KSI84AP-x-10k-x and KSI84AR-x-x-5

<sup>5)</sup> [Settling time](#) for average filter= auto, 1...5 (0,125...0,6) s optionally available



| 5.4 Environmental Characteristics |                                     |                   |    |
|-----------------------------------|-------------------------------------|-------------------|----|
| Operating temperature             | T <sub>min</sub> / T <sub>max</sub> | -40 / 100         | °C |
| Protection grade                  |                                     | IP68              |    |
| Destruction shock limit           | a <sub>max</sub>                    | 5000              | g  |
| EMI                               |                                     | EN 61326-2-3:2013 |    |

## 5.5 Type Tables

### 5.5.1 Acceleration, RMS

| Q | M   | HP<br>Hz             | LP<br>Hz                                     | Range<br>m/s <sup>2</sup> | Type code          | Noise<br>m/s <sup>2</sup> |
|---|-----|----------------------|--|---------------------------|--------------------|---------------------------|
| a | RMS | 1,5                  | 100<br>300<br>1k                             | 5                         | KSI84AR-1-LP-5     | 0,005                     |
|   |     |                      |  | 10                        | KSI84AR-1-LP-10    | 0,005                     |
|   |     |                      |  | 20                        | KSI84AR-1-LP-20    | 0,005                     |
|   |     |                      |  | 50                        | KSI84AR-1-LP-50    | 0,007                     |
|   |     |                      |  | 100                       | KSI84AR-1-LP-100   | 0,007                     |
|   |     |                      |  | 200                       | KSI84AR-1-LP-200   | 0,008                     |
|   |     |                      |  | 500                       | KSI84AR-1-LP-500   | 0,016                     |
|   |     |                      | 5k   | 10                        | KSI84AR-1-5k-10    | 0,020                     |
|   |     |                      |  | 20                        | KSI84AR-1-5k-20    | 0,020                     |
|   |     |                      |  | 50                        | KSI84AR-1-5k-50    | 0,030                     |
|   |     |                      |  | 100                       | KSI84AR-1-5k-100   | 0,060                     |
|   |     |                      |  | 200                       | KSI84AR-1-5k-200   | 0,080                     |
|   |     |                      |  | 500                       | KSI84AR-1-5k-500   | 0,160                     |
|   |     |                      | 10k  | 20                        | KSI84AR-1-10k-20   | 0,050                     |
|   |     |                      |  | 50                        | KSI84AR-1-10k-50   | 0,090                     |
|   |     |                      |  | 100                       | KSI84AR-1-10k-100  | 0,180                     |
|   |     |                      |  | 200                       | KSI84AR-1-10k-200  | 0,200                     |
|   |     |                      |  | 500                       | KSI84AR-1-10k-500  | 0,250                     |
|   |     | 3<br>10<br>30<br>100 | 100 <sup>1)</sup><br>300 <sup>1)</sup><br>1k | 5                         | KSI84AR-HP-LP-5    | 0,005                     |
|   |     |                      |  | 10                        | KSI84AR-HP-LP-10   | 0,005                     |
|   |     |                      |  | 20                        | KSI84AR-HP-LP-20   | 0,005                     |
|   |     |                      |  | 50                        | KSI84AR-HP-LP-50   | 0,007                     |
|   |     |                      |  | 100                       | KSI84AR-HP-LP-100  | 0,007                     |
|   |     |                      |  | 200                       | KSI84AR-HP-LP-200  | 0,008                     |
|   |     |                      |  | 500                       | KSI84AR-HP-LP-500  | 0,016                     |
|   |     | 1k                   | 10k  | 20                        | KSI84AR-1k-10k-20  | 0,050                     |
|   |     |                      |  | 50                        | KSI84AR-1k-10k-50  | 0,090                     |
|   |     |                      |  | 100                       | KSI84AR-1k-10k-100 | 0,180                     |
|   |     |                      |  | 200                       | KSI84AR-1k-10k-200 | 0,200                     |
|   |     |                      |  | 500                       | KSI84AR-1k-10k-500 | 0,250                     |

<sup>1)</sup> The condition LP ≥ 10 HP must be met

### 5.5.2 Acceleration, PEAK

| Q | M    | HP<br>Hz             | LP<br>Hz                                     | Range<br>m/s <sup>2</sup> pk | Type code         | Noise<br>m/s <sup>2</sup> pk |
|---|------|----------------------|--|------------------------------|-------------------|------------------------------|
| a | Peak | 1.5                  | 100<br>300<br>1k                             | 10                           | KSI84AP-1-LP-10   | 0.005                        |
|   |      |                      |  | 20                           | KSI84AP-1-LP-20   | 0.005                        |
|   |      |                      |  | 50                           | KSI84AP-1-LP-50   | 0.007                        |
|   |      |                      |  | 100                          | KSI84AP-1-LP-100  | 0.007                        |
|   |      |                      |  | 200                          | KSI84AP-1-LP-200  | 0.008                        |
|   |      |                      |  | 500                          | KSI84AP-1-LP-500  | 0.016                        |
|   |      |                      | 5k   | 10                           | KSI84AP-1-5k-10   | 0.020                        |
|   |      |                      |  | 20                           | KSI84AP-1-5k-20   | 0.020                        |
|   |      |                      |  | 50                           | KSI84AP-1-5k-50   | 0.030                        |
|   |      |                      |  | 100                          | KSI84AP-1-5k-100  | 0.060                        |
|   |      |                      |  | 200                          | KSI84AP-1-5k-200  | 0.080                        |
|   |      |                      |  | 500                          | KSI84AP-1-5k-500  | 0.160                        |
|   |      |                      | 10k  | 50                           | KSI84AP-1-10k-50  | 0.090                        |
|   |      |                      |  | 100                          | KSI84AP-1-10k-100 | 0.180                        |
|   |      |                      |  | 200                          | KSI84AP-1-10k-200 | 0.200                        |
|   |      | 500                  |  | KSI84AP-1-10k-500            | 0.250             |                              |
|   |      | 3<br>10<br>30<br>100 | 100 <sup>1)</sup><br>300 <sup>1)</sup><br>1k | 10                           | KSI84AP-HP-LP-10  | 0.005                        |
|   |      |                      |  | 20                           | KSI84AP-HP-LP-20  | 0.005                        |
|   |      |                      |  | 50                           | KSI84AP-HP-LP-50  | 0.007                        |
|   |      |                      |  | 100                          | KSI84AP-HP-LP-100 | 0.007                        |
|   |      |                      |  | 200                          | KSI84AP-HP-LP-200 | 0.008                        |
|   |      |                      |  | 500                          | KSI84AP-HP-LP-500 | 0.016                        |
|   |      |                      |  | 1k                           | 10k               | 50                           |
|   |      | 100                  | KSI84AP-1k-10k-100                           |                              |                   | 0.180                        |
|   |      | 200                  | KSI84AP-1k-10k-200                           |                              |                   | 0.200                        |
|   |      | 500                  | KSI84AP-1k-10k-500                           |                              |                   | 0.250                        |

<sup>1)</sup> The condition  $LP \geq 10$  HP must be met

### 5.5.3 Velocity, RMS

| Q | M   | HP<br>Hz | LP<br>Hz          | Range<br>mm/s | Type code       | Noise<br>mm/s |
|---|-----|----------|-------------------|---------------|-----------------|---------------|
| v | RMS | 1,5      | 100<br>300,<br>1k | 40            | KSI84VR-1-LP-40 | 0,100         |
|   |     |          |                   | 50,8          | KSI84VR-1-LP-50 |               |
|   |     | 3        | 100<br>300<br>1k  | 20            | KSI84VR-3-LP-20 | 0,035         |
|   |     |          |                   | 25,4          | KSI84VR-3-LP-25 |               |
|   |     |          |                   | 40            | KSI84VR-3-LP-40 |               |
|   |     |          |                   | 50,8          | KSI84VR-3-LP-50 |               |

## Velocity, RMS (continued)

| Q | M | HP<br>Hz         | LP<br>Hz                       | Range<br>mm/s | Type code        | Noise<br>mm/s |
|---|---|------------------|--------------------------------|---------------|------------------|---------------|
|   |   | 10 <sup>1)</sup> | 100<br>300<br>1k <sup>1)</sup> | 10            | KSI84VR-10-LP-10 | 0,010         |
|   |   |                  |                                | 12,7          | KSI84VR-10-LP-12 |               |
|   |   |                  |                                | 20            | KSI84VR-10-LP-20 |               |
|   |   |                  |                                | 25,4          | KSI84VR-10-LP-25 |               |
|   |   |                  |                                | 40            | KSI84VR-10-LP-40 |               |
|   |   |                  |                                | 50,8          | KSI84VR-10-LP-50 |               |
|   |   | 30               | 300<br>1k                      | 10            | KSI84VR-30-LP-10 | 0,005         |
|   |   |                  |                                | 12,7          | KSI84VR-30-LP-12 |               |
|   |   |                  |                                | 20            | KSI84VR-30-LP-20 |               |
|   |   |                  |                                | 25,4          | KSI84VR-30-LP-25 |               |
|   |   |                  |                                | 40            | KSI84VR-30-LP-40 |               |
|   |   |                  |                                | 50,8          | KSI84VR-30-LP-50 |               |

<sup>1)</sup> Complies with the requirements of [ISO 2954](#)

## 5.5.4 Velocity, PEAK

| Q | M    | HP<br>Hz | LP<br>Hz         | Range<br>mm/s pk | Type code        | Noise<br>mm/s pk |
|---|------|----------|------------------|------------------|------------------|------------------|
| v | Peak | 10       | 100<br>300<br>1k | 20               | KSI84VP-10-LP-20 | 0.010            |
|   |      |          |                  | 25.4             | KSI84VP-10-LP-25 |                  |
|   |      |          |                  | 40               | KSI84VP-10-LP-40 |                  |
|   |      |          |                  | 50.8             | KSI84VP-10-LP-50 |                  |
|   |      | 30       | 300<br>1k        | 10               | KSI84VP-30-LP-10 | 0.005            |
|   |      |          |                  | 12.7             | KSI84VP-30-LP-12 |                  |
|   |      |          |                  | 20               | KSI84VP-30-LP-20 |                  |
|   |      |          |                  | 25.4             | KSI84VP-30-LP-25 |                  |
|   |      |          |                  | 40               | KSI84VP-30-LP-40 |                  |
|   |      |          |                  | 50.8             | KSI84VP-30-LP-50 |                  |

## 5.5.5 Displacement

| Q | M             | HP<br>Hz | LP<br>Hz | Range<br>mm pk-pk | Type code       | Noise<br>mm pk-pk |
|---|---------------|----------|----------|-------------------|-----------------|-------------------|
| d | Peak-<br>Peak | 3        | 300      | 10                | KSI84D-3-300-10 | 0,016             |
|   |               |          |          | 12,7              | KSI84D-3-300-12 | 0,020             |
|   |               |          |          | 20                | KSI84D-3-300-20 | 0,032             |
|   |               |          |          | 25,4              | KSI84D-3-300-25 | 0,040             |
|   |               |          |          | 40                | KSI84D-3-300-40 | 0,064             |
|   |               |          |          | 50,8              | KSI84D-3-300-50 | 0,080             |

# 5.6 Dimensions

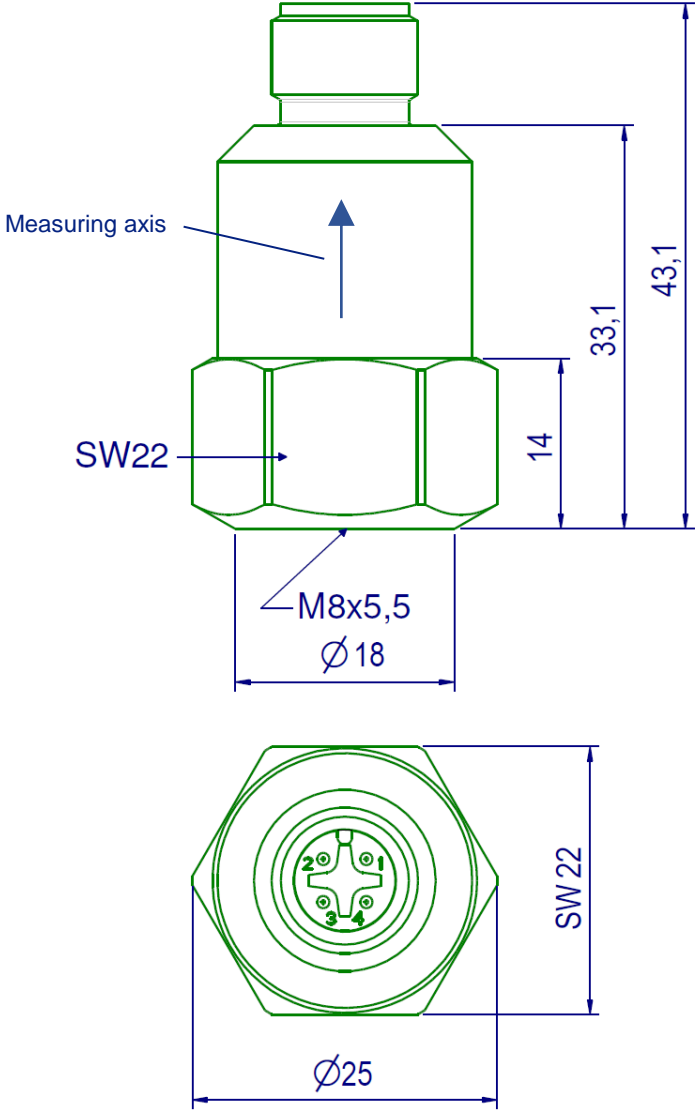

## Limited Warranty

Metra warrants for a period of

**24 months**

that its products will be free from defects in material or workmanship and shall conform to the specifications current at the time of shipment.

The warranty period starts with the date of invoice.

The customer must provide the dated bill of sale as evidence.

The warranty period ends after 24 months.

Repairs do not extend the warranty period.

This limited warranty covers only defects which arise as a result of normal use according to the instruction manual.

Metra's responsibility under this warranty does not apply to any improper or inadequate maintenance or modification and operation outside the product's specifications.

Shipment to Metra will be paid by the customer.

The repaired or replaced product will be sent back at Metra's expense.

## Declaration of Conformity

According to EMC Directive 2014/30/EC

Product: Vibration Sensor

Type: KSI84xx

It is hereby certified that the above mentioned product complies with the demands pursuant to the following standards:

EN 61326-2-3:2013

EN61000-6-4:2006 + A1:2011

EN61000-6-2:2005

The producer is responsible for this declaration

Manfred Weber Metra Mess- und Frequenztechnik in Radebeul e.K.  
Meissner Str. 58, D-01445 Radebeul

declared by:



Michael Weber, Radebeul, July 28, 2020