



## XS-D SERIES

### High stroke-to-length ratio LVDT

#### SPECIFICATIONS

- ◆ Excellent stroke-to-length ratio
- ◆ Lower weights than other standard LVDTs with comparable displacement ranges
- ◆ Stroke ranges from  $\pm 1$  to  $\pm 10$  inches
- ◆ Shock and vibration tolerant
- ◆ Stainless steel housing
- ◆ Magnetically shielded
- ◆ Imperial or metric threaded core

The XS-D Series LVDTs are specifically designed for measuring relatively large displacements where installation space is limited. The XS-D Series have a substantially greater displacement range than other standard LVDTs, but without the accompanying increase in body length and weight. Using special coil winding techniques, the XS-D permits linear range measurements of up to 80% of the housing length.

Compact, shock and vibration tolerant, and featuring infinite resolution and repeatability, the XS-D Series are the perfect choice for servo mechanisms, linear potentiometer replacement, or wherever precise displacement measurements are required in space restrictive applications. All models are supplied with a calibration certificate, and are available with either an imperial or metric threaded core. The XS-D Series are compatible with all Measurement Specialties LVDT signal conditioners, controllers and readouts.

Like in most of our LVDTs, the XS-D windings are vacuum impregnated with a specially formulated, high temperature, flexible resin, and the coil assembly is potted inside its housing with a two-component epoxy. This provides excellent protection against hostile environments such as high humidity, vibration and shock.

#### FEATURES

- ◆ Superior stroke-to-length ratio
- ◆ Stroke ranges from  $\pm 1$  to  $\pm 10$  inches
- ◆ Smooth transfer function
- ◆ AISI 400 Series stainless steel housing
- ◆ Calibration certificate supplied with all units

#### APPLICATIONS

- ◆ Servo mechanisms
- ◆ Hydraulic actuators
- ◆ Linear potentiometer replacement
- ◆ Space restrictive installations
- ◆ Weight sensitive applications

**XS-D SERIES**

High stroke-to-length ratio LVDT

**PERFORMANCE SPECIFICATIONS**

<b>ELECTRICAL SPECIFICATIONS</b>					
<b>Parameter</b>	<b>XS-D 1002</b>	<b>XS-D 2002</b>	<b>XS-D 3002</b>	<b>XS-D 5002</b>	<b>XS-D 10002</b>
Stroke range	±1 [±25.4]	±2 [±50.8]	±3 [±76.2]	±5 [±127]	±10 [±254]
Sensitivity V/V/inch [mV/V/mm]	0.28 [11.0]	0.16 [6.3]	0.12 [4.7]	0.13 [5.1]	0.05 [2.0]
Output at stroke ends (*)	280mV/V	320mV/V	360mV/V	650mV/V	500mV/V
Phase shift	+30°	+25°	+7°	+0.5°	-4°
Input impedance (PRIMARY)	175Ω	243Ω	266Ω	968Ω	628Ω
Output impedance (SECONDARY)	230Ω	103Ω	220Ω	532Ω	416Ω
Non-linearity	±2.0% of FR, maximum				
Input voltage	3 VRMS sine wave				
Test input frequency	2.5kHz				
Input frequency range	400Hz to 3kHz				
Null voltage	0.5% of FRO, maximum				

<b>ENVIRONMENTAL SPECIFICATIONS &amp; MATERIALS</b>	
Operating temperature	-65°F to +300°F [-55°C to 150°C]
Shock survival	1,000 g (11ms half-sine)
Vibration tolerance	20 g up to 2KHz
Housing material	AISI 410 Series stainless steel
Electrical connection	Six lead-wires, stranded 28 AWG, PTFE insulated, 1 foot [0.3m] long
IEC 60529 rating	IP61

**Notes:***Dimensions are in inch [mm]**All values are nominal unless otherwise noted**Electrical specifications are for the test frequency indicated in the table**(\*): Unit for output at stroke ends is millivolt per volt of excitation (input voltage)**FR: Full Range is the stroke range, end to end; FR=2xS for ±S stroke range**FRO (Full Range Output): Algebraic difference in outputs measured at the ends of the range*

## XS-D SERIES

High stroke-to-length ratio LVDT

### MECHANICAL SPECIFICATIONS

Parameter	XS-D 1002	XS-D 2002	XS-D 3002	XS-D 5002	XS-D 10002
Main body length "A"	2.57 [65.2]	5.76 [146.3]	7.50 [190.5]	12.52 [318.0]	25.06 [636.5]
Core length "B"	0.45 [11.4]	1.50 [38.1]	1.25 [31.8]	2.40 [61.0]	4.00 [101.6]
Bore diameter "D"	0.265 [6.73]	0.265 [6.73]	0.30 [7.62]	0.30 [7.62]	0.35 [8.89]
Body weight, oz [g]	2.3 [65]	4.1 [115]	4.9 [140]	7.6 [215]	16.6 [470]
Core weight, oz [g]	0.09 [2.5]	0.28 [8.0]	0.24 [6.8]	0.44 [12.5]	0.88 [25.0]

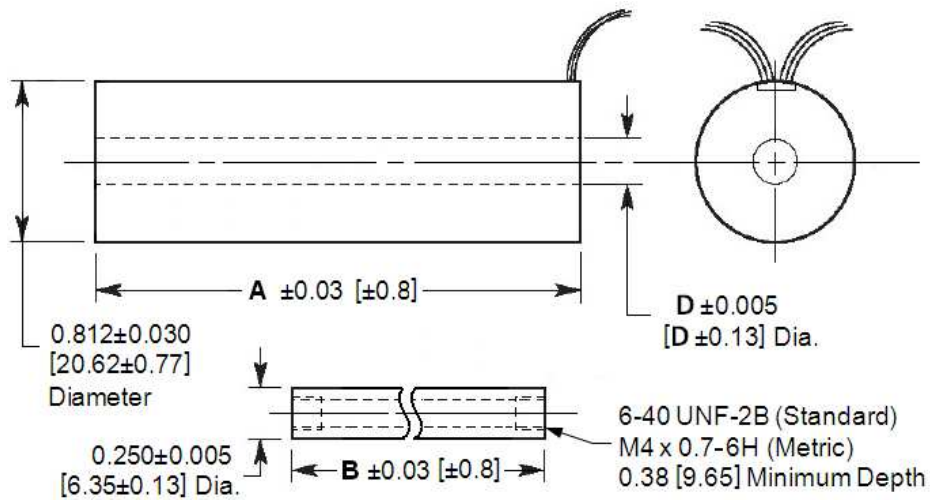

Dimensions are in inches [mm]

### WIRING INFORMATION

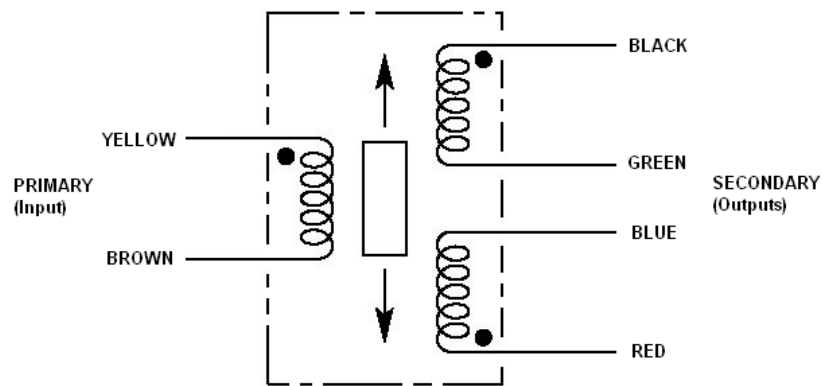

Connect Green to Blue for differential output

**XS-D SERIES**

High stroke-to-length ratio LVDT

**ORDERING INFORMATION**

Description	Model	Part Number
±1 inch LVDT	XS-D1002	02560567-000
±2 inch LVDT	XS-D2002	02560568-000
±3 inch LVDT	XS-D3002	02560569-000
±5 inch LVDT	XS-D5002	02560571-000
±10 inch LVDT	XS-D10002	02560572-000

**OPTIONS**

Description	Model	Part Number
Metric threaded core option (M4x0.7-6H threads)	All	XXXXXXXX-006

**ACCESSORIES**

Description	Part Number
Core connecting rod, 6 inches long, 6-40 threads	05282947-006
Core connecting rod, 12 inches long, 6-40 threads	05282947-012
Core connecting rod, 24 inches long, 6-40 threads	05282947-024
Core connecting rod, 36 inches long, 6-40 threads	05282947-036
Core connecting rod, 6 inches long, M4x0.7 metric threads	05282978-006
Core connecting rod, 12 inches long, M4x0.7metric threads	05282978-012
Mounting block	04560952-000