



Technical data



5 INCH
DISPLAY



800 NIT
SUNLIGHT
READABLE



PCAP



800
x 480
RESOLUTION



IP 67
INGRESS
PROTECTION



+ 70°
- 20°
OPERATING
TEMP



1 X ANALOGUE
INPUT



1 X DIGITAL
INPUT



ETHERNET



2 X
PORTS



1X RELAY
OUTPUT



RS422
1 X RS422/485



CAN
2 X
CAN BUS

T5

5" TOUCH DISPLAY

FORMERLY THE CANVU™ 500, IS PART OF THE T SERIES, HOUSING A TOUCH, CUSTOMISABLE, COLOUR SCREEN

The T5 has a slim-line profile housing a hi-resolution 5-inch projected capacitive touch customisable colour screen delivering modern tablet like aesthetics.

The WVGA (800x480) PCAP LCD colour display can be viewed in full sunlight and the ruggedised unit is sealed to meet IP67 standards. With dual CAN and Ethernet the display is suited to a wide range of applications. External buttons can be added via a compatible CAN keypad.

It meets the need for tough, flexible instrumentation while offering high performance and design specifications. Custom software applications to be rapidly created using the software development kit (SDK), and the display can be integrated into a control & monitoring system using its data logging capacity, and alarm functionality.

Running linux, programmers can quickly put together a project using our proprietary software developer's kit (SDK) and the proven Veethree component based library. Application software is able to be rapidly validated on a PC using the PC simulator.



Reliability

Our products continue to be successfully deployed in an enormously diverse range of applications where total reliability is vital.

All products, bespoke or standard range are backed up by a dedicated central team of specialist engineers able to rapidly adapt any product for a specific application and to provide an unrivalled level of customer support.

Displays are also supported with a return to base extended 24-month Manufacture warranty against mechanical failure or material defects.



Software

Our SDK is offered for a one-off licence fee from which customers can develop their own bespoke application solution. Available are optional plugins for J1939, NMEA 2000, and support hours are included should your engineers need any help along the way.

Alternatively, we can develop bespoke software to your specification using our experienced in house engineers.

Over the years our engineers have developed software for our displays to run rock crushers & mining machinery, measure performance of spraying equipment, acting as battery monitors, boat gyro stabilisers, plus many more including military and aerospace applications.

Also available is our Engine Monitor standard software for Industrial and Marine, which can be pre-loaded to our displays receiving and displaying J1939 engine and transmission data, including common Tier4 parameters, with active alarms (from DM1) & NMEA 2000 data, where supported.

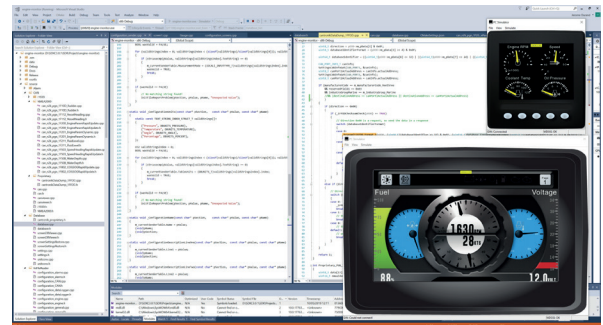

Accessories

- > Cable Harnesses
- > Front Mounting Kits
- > CAN Keypad
- > Branding - Labels & Boxes
- > GPS Sensor
- > Development Harness



Specifications

Hardware

CPU	i.MX6 Solo X
FLASH Memory	512MB SLC NAND
SDRAM	256MB DDR3

Electrical

Display	PCAP LCD 5.0"
Resolution	800 (H) x 480 (V) WVGA
Active Area	108.0mm (H) x 64.8mm (V)
Viewing Angle	70 degrees left/right/down/up
Contrast Ratio	700:1
Brightness	800 NIT (cd/m ²) Full sunlight readable
Power Requirements	8V to 32V DC
Sounder	Internal Buzzer
Connection	5 x M12 Connectors A - Primary CANbus / Power M12 Male 5 pin A coded B - Isolated CANbus M12 Male 5 pin A coded C - Ethernet M12 Female 4 pin D coded D - Misc M12 Female 12 pin A coded

Mechanical

Case material	ABS
Case colour	Anthracite Grey
Dimensions	133mm (W) x 94mm (H) x 11mm forward and 48mm rear (D)

Input/Output / Communications

Analogue Input	Software selectable as 0 - 2.5 VDC, 0 - 10 VDC or 0 - 10 VDC or 0 - 1000 OHMS
Switch Inputs	Switch Contact to ground or open collector type sensor - max. frequency = 50 Hz
Relay Output	Open collector suitable 0.5A continuous load.
Communications	1 x RS422/485, 2 x CAN Bus 2.0B (1 isolated) 1 x USB 2.0, 1 x Ethernet

Environmental

Operating temperature	-20°C to +70°C
Storage Temperature	-30°C to +80°C
Degree of Protection	IP67

Part Number

5000	T5 5" CAN Display
5001	T5 5" CAN Display with Engine Monitor Software Preloaded





Connectors (Version No. 06)

CAN1

1	No Connection
2	Positive DC Supply
3	Ground
4	CAN Data H
5	CAN Data L

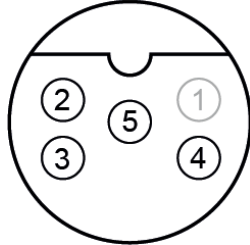

CAN2

1	No Connection
2	Isolated Volts Positive
3	Isolated Volts Negative
4	Isolated CAN Data H
5	Isolated CAN Data L

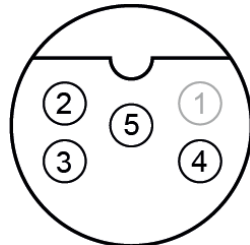

Ethernet

1	White/Orange +TK
2	White/Green +RX
3	Orange - TX
4	Green

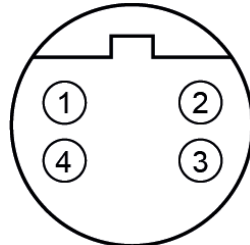

External USB IO

1	USB Volts Positive
2	USB Data Negative (DM)
3	USB Data Positive (DP)
4	No Connection
5	USB Volts Negative
6	RS422/485 Tx+*
7	RS422/485 Tx-*
8	RS422/485 Rx+*
9	RS422/485 Rx-*
10	Digital Input
11	Analogue Input
12	Relay Output

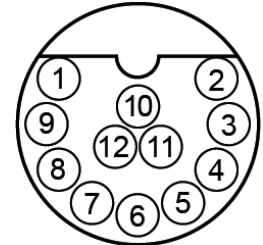

*RS422 and RS485 options configured as a build option

Dimensions

FRONT VIEW

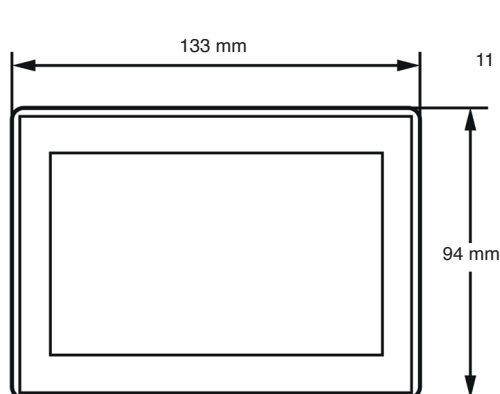

SIDE VIEW

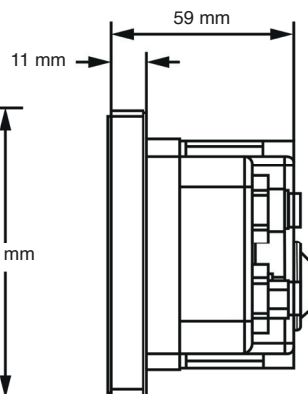

REAR VIEW

