

- **Robust design based on inductive technology**
- **Sleeve or threaded core options**
- **Optimal sensor length to cylinder stroke ratio**
- **8mm transducer body diameter**
- **Internal or external threaded flange options**
- **Measurement range 25-1000mm**
- **Integrated signal conditioning electronics**
- **Analog Output (ICT800) – 0.5-4.5Vdc or 0.2-4.8Vdc**
- **CAN Output (ICT820) – SAE J1939**
- **Approaching end-of-stroke signaling**
- **Hydraulic fluid temperature measurement**
- **Self-diagnostics and safety outputs**
- **Sealing to IP69K**



The ICT800 & 820 range of Contactless In-Cylinder Linear Transducers offers an unmatched combination of ruggedness and long life. The non-contacting, inductive sensing design provides superior resistance to shock and vibration that other technologies, such as magnetostrictive, simply can't match; as well as eliminating the potential reliability issues related to contacting parts used in potentiometer based products.

Two core configurations provide the designer the following options:

Sleeved Core - cylinder rods can be simply machined to accommodate the sleeve. This also gives the option of retro-fitting existing servo-cylinders with an upgrade to ICT technology.

Threaded Core - provides the designer with the minimum transducer body size and simplified installation requiring minimal machining.

Because inductive sensing elements can provide measurement right up to the end-stops, there are no dead zones meaning the overall sensor length can be as close as possible to the cylinder's stroke. This, coupled with careful mechanical design, eases accommodation of the sensor into cylinders where space is at a premium.

Furthermore, with a transducer body of only 8mm the ICT800 & 820 are well suited for use on small-bore actuators; while offering a choice of internal or threaded external flange mounting configurations to suit tie-rod, welded and rear clevis-mounted cylinder types in stroke ranges from 25 to 1000mm.

The signal conditioning electronics, which can operate from a 5Vdc or an 8-30Vdc supply and across a wide temperature range, are integrated into the mounting flange and provide analog or CAN SAE J1939 output options. The analog output can be chosen to provide output ranges of 0.5-4.5Vdc or 0.2-4.8Vdc, while the CAN models have multiple Node ID, Baud Rate and Frame Rate configurations, thereby allowing simple integration with existing networks.

To maximise sensor safety, internal diagnostic circuits monitor for correct operation and if an error is detected this is communicated via an out-of-range analog signal or with a CAN message. In addition, the CAN versions are able to provide information on hydraulic fluid temperature, as well as having programmable end-stops and indication that the cylinder is approaching the end of travel, so allowing automatic soft-stopping. Dependent on electrical connector configuration, environmental protection levels of IP69K can be achieved.



Contents

Configuration & Ordering Codes – ICT800..... 4

- Flange 4
- Core 4
- Electrical Stroke (Maximum) 4
- Low Output Position..... 4
- High Output Position..... 5
- Output..... 5
- Connections 5

Configuration & Ordering Codes – ICT820..... 6

- Mode 6
- Flange 6
- Core 6
- Electrical Stroke (Maximum) 6
- Low Output Position..... 6
- High Output Position..... 7
- Baud Rate 7
- Node ID 7
- Frame Rate 7
- Connections 8

Installation 9

- Mechanical – External Flange..... 9
- Mechanical – Internal Flange..... 10
 - Flange Details 11
- Electrical Connections 12
 - M12 Connector (C01)..... 12
 - Cable with Gland (BXX) – ICT800..... 12
 - Cable with Gland (BXX) – ICT820..... 13
 - Flying Leads (FXX) 13
- Installation Kit 14
- Materials Used..... 14



Specifications.....15

 Electrical.....15

 Voltage Output – ICT80015

 CAN Output – ICT820.....16

 Environmental.....17

Installation Guidelines for Internal Flange18

© 2020 Curtiss-Wright. All rights reserved.

Curtiss-Wright accepts no responsibility for possible errors in catalogs, brochures and other printed material. Curtiss-Wright reserves the right to alter its products without prior notice. This also applies to products already ordered provided that such alterations can be made without affecting agreed specifications. All trademarks in this material are properties of their respective owners.

**CONFIGURATION & ORDERING CODES – ICT800**

ICT800-X-X-XXXX-XXXX-XXXX-XX-XXX

Type	Flange	Core	Electrical Stroke (Maximum)	Low Output Position	High Output Position	Output	Connections
ICT800	X	X	XXXX	XXXX	XXXX	XX	XXX
	I	S	XXXX	XXXX	XXXX	A1	C01
	E	T				A5	BXX
							FP2
							FP5
							F01

FLANGE

ICT800-X-X-XXXX-XXXX-XXXX-XX-XXX

Code	Description
I	Internal
E	External

CORE

ICT800-X-X-XXXX-XXXX-XXXX-XX-XXX

Code	Description
S	Sleeve
T	Threaded

ELECTRICAL STROKE (MAXIMUM)

ICT800-X-X-XXXX-XXXX-XXXX-XX-XXX

Code	Description
XXXX	25-200 mm in 5 mm increments, 210-1000 mm in 10 mm increments

LOW OUTPUT POSITION

ICT800-X-X-XXXX-XXXX-XXXX-XX-XXX

Code	Description
XXXX	25-1000 mm in 1 mm increments (see page 15 for further information and output law examples)



HIGH OUTPUT POSITION

ICT800-X-X-XXXX-XXXX-XXXX-XX-XXX

Code	Description
XXXX	25-1000 mm in 1 mm increments (see page 15 for further information and output law examples)

OUTPUT

ICT800-X-X-XXXX-XXXX-XXXX-XX-XXX

Code	Description
A1	Analog voltage: 10-90% of 5V supply or 0.5-4.5V of 9-32V supply
A5	Analog voltage: 4-96% of 5V supply or 0.2-4.8V of 9-32V supply

CONNECTIONS

ICT800-X-X-XXXX-XXXX-XXXX-XX-XXX

Code	Description
C01	Flange mounted M12 connector
BXX	Cable with gland, XX = cable length - 01-06 metres in 1 m increments
FP2	Flying leads 200mm
FP5	Flying leads 500mm
F01	Flying leads 1000mm

NOTES

C01 and BXX options with external flange only.
FPX options with internal flange only.



CONFIGURATION & ORDERING CODES – ICT820

ICT820-X-X-XXXX-XXXX-XXXX-X-XX-X-XXX

Type	Mode	Flange	Core	Electrical Stroke (Maximum)	Low Output Position	High Output Position	Baud Rate	Node ID	Frame Rate	Connections
ICT820	X	X	X	XXXX	XXXX	XXXX	X	XX	X	XXX
	J	I	S	XXXX	XXXX	XXXX	1	XX	1	C01
		E	T				2		2	BXX
							3		3	FP2
							4		4	FP5
							5		5	F01
									6	
									7	
									8	
									9	
									0	

MODE

ICT820-~~X~~-X-X-XXXX-XXXX-XXXX-X-XX-X-XXX

Code	Description
J	SAE J1939

FLANGE

ICT820-X-X-~~X~~-XXXX-XXXX-XXXX-X-XX-X-XXX

Code	Description
I	Internal
E	External

CORE

ICT820-X-X-X-~~X~~-XXXX-XXXX-XXXX-X-XX-X-XXX

Code	Description
S	Sleeve
T	Threaded

ELECTRICAL STROKE (MAXIMUM)

ICT820-X-X-X-~~XXXX~~-XXXX-XXXX-X-XX-X-XXX

Code	Description
XXXX	25-200mm in 5mm increments, 210-1000mm in 10mm increments

LOW OUTPUT POSITION

ICT820-X-X-X-XXXX-XXXX-XXXX-X-XX-X-XXX

Code	Description
XXXX	25-1000 mm in 1 mm increments (see page 16 for further information and output law examples)

HIGH OUTPUT POSITIONICT820-X-X-X-XXXX-XXXX-XXXX-X-XX-X-XXX

Code	Description
XXXX	25-1000 mm in 1 mm increments (see page 16 for further information and output law examples)

BAUD RATEICT820-X-X-X-XXXX-XXXX-XXXX-X-XX-X-XXX

Code	Description
1	50kbits/s
2	125kbits/s
3	250kbits/s
4	500kbits/s
5	1000kbits/s

NODE IDICT820-X-X-X-XXXX-XXXX-XXXX-X-XX-X-XXX

Code	Description
XX	01-7F in hexadecimal

FRAME RATEICT820-X-X-X-XXXX-XXXX-XXXX-X-XX-X-XXX

Code	Description
1	10ms
2	20ms
3	30ms
4	40ms
5	50ms
6	60ms
7	70ms
8	90ms
9	90ms
0	100ms



CONNECTIONS

ICT820-X-X-X-XXXX-XXXX-XXXX-XX-XXX

Code	Description
C01	Flange mounted M12 connector
BXX	Cable with gland, XX = cable length - 01-06 metres in 1 m increments
FP2	Flying leads 200mm
FP5	Flying leads 500mm
F01	Flying leads 1000mm

NOTES

C01 and BXX options with external flange only.
FPX options with internal flange only.



INSTALLATION

For more detail of cylinder and piston machining, refer to Instruction Document, AI209399, supplied with each sensor.

MECHANICAL – EXTERNAL FLANGE

For Detail A, see section Flange Details.

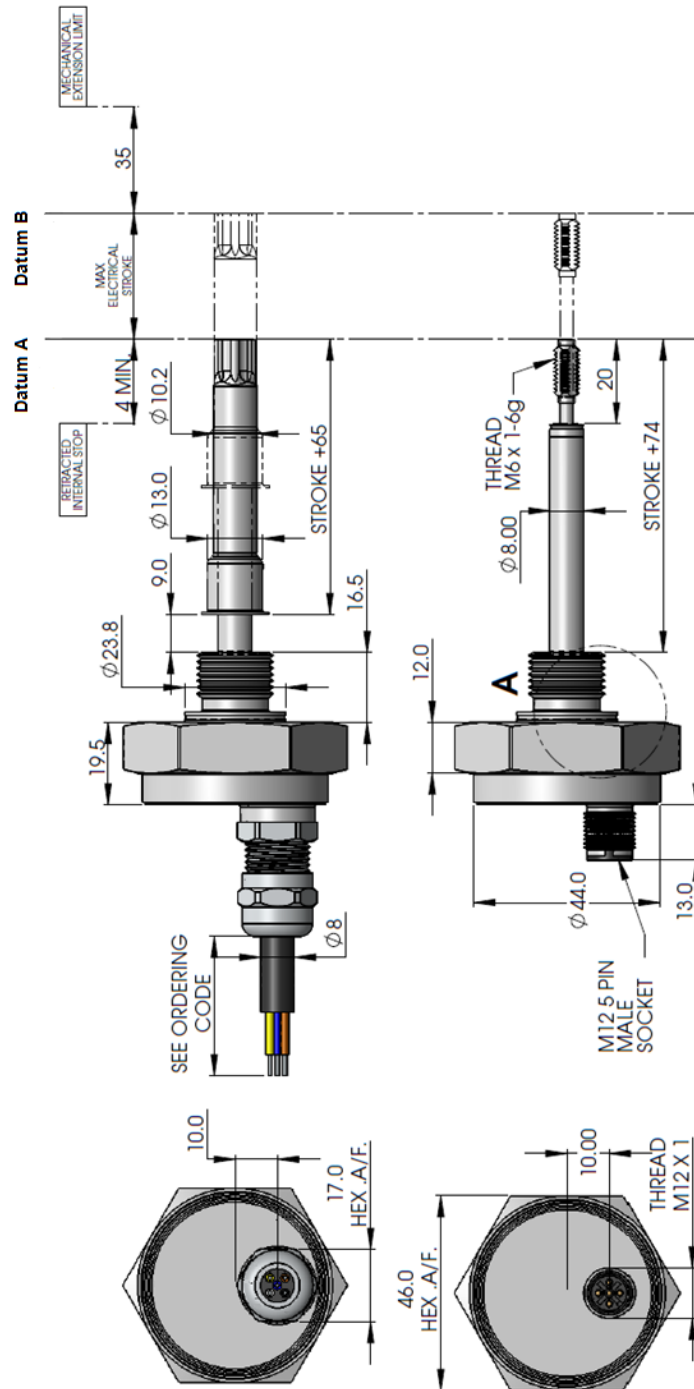



MECHANICAL – INTERNAL FLANGE

For Detail B, see section Flange Details.

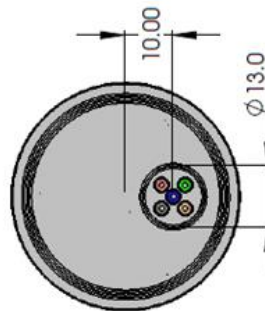
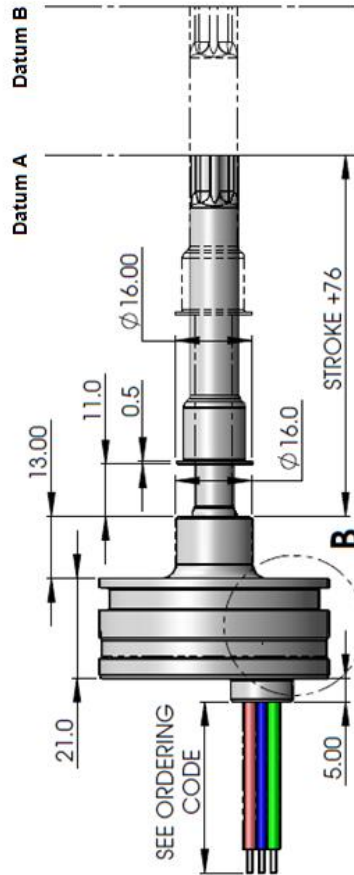



Flange Details

External – Detail A

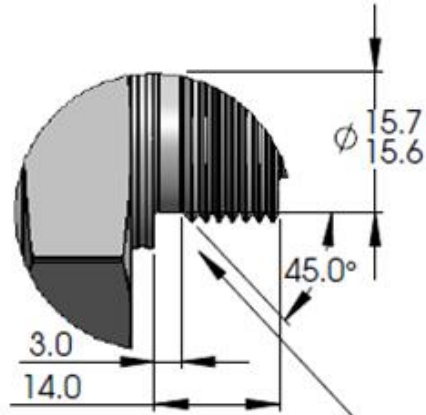

(THE DETAILS IN THIS REGION CONFORM TO ISO6149/2 M18 X 1.5 FOR WHICH PORT CUTTERS ARE AVAILABLE)

Internal – Detail B

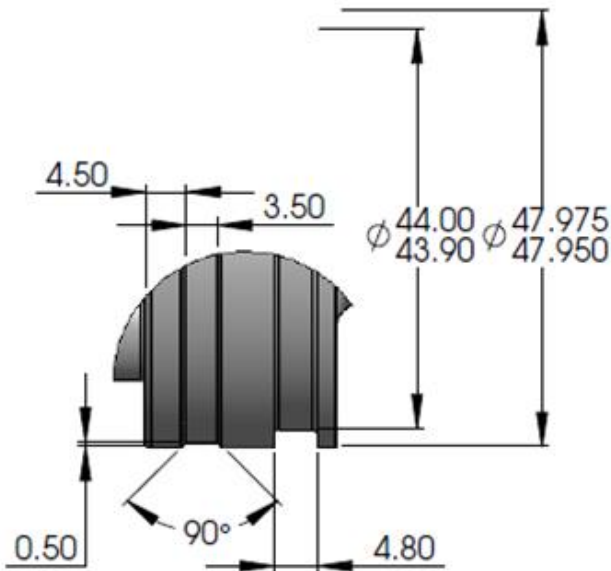



ELECTRICAL CONNECTIONS

M12 Connector (C01)

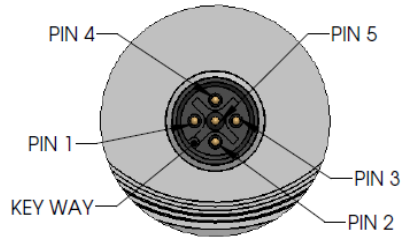

Pin	Function	
1	ICT800: Output	ICT820: Not connected
2	ICT800: Vsupply	ICT820: Vsupply
3	ICT800: GND (0V)	ICT820: GND (0V)
4	ICT800: Not connected	CAN High
5	ICT800: Not connected	CAN Low

Mating connector SA210517/MKx also available where x = 1, 5 or 10 for 1 m, 5 m, or 10 m cable length

Cable with Gland (BXX) – ICT800

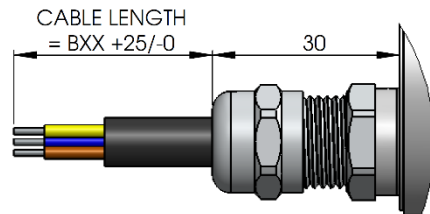

Color	Function
BLUE	Not connected
BROWN	Vsupply
BLACK	Output
WHITE	Not connected
GREY	GND (0V)



Cable with Gland (BXX) – ICT820

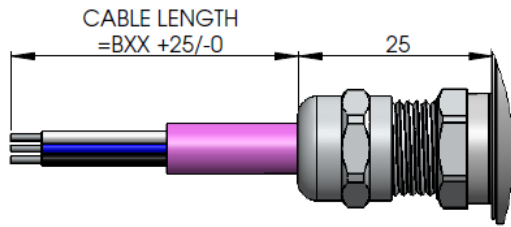

Color	Function
BLUE	CAN Low
RED	Vsupply
WHITE	CAN High
BLACK	GND (0V)

Flying Leads (FXX)

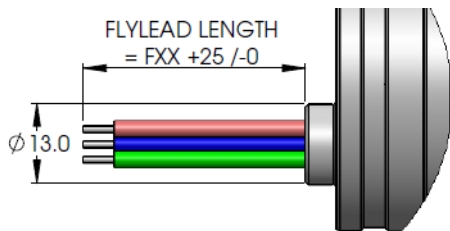

Color	Function	
BLUE	ICT800: Not connected	ICT820: CAN Low
BROWN	ICT800: Vsupply	ICT820: Vsupply
BLACK	ICT800: Output	ICT820: Not connected
RED	ICT800: Not connected	ICT820: CAN High
GREEN	ICT800: GND (0V)	ICT820: GND (0V)



INSTALLATION KIT

Each sensor is supplied with an Installation Kit comprising:

Item	Description	Quantity
1	O-ring (15.3 x 2.2mm)	1
2	O-ring (44 x 2.5mm)	1
3	Anti-extrusion ring	1
4	Wavy washer	3
5	Shim washer	1
6	Circlip	1
7	M5 x 10mm hex socket screw	1
8	M6 nut	1
9	Instruction document	1

MATERIALS USED

	Material	Component
All Variants	Stainless Steel 316	Body (case)
		Sleeve
		Guide tube
Cable with Gland	Stainless Steel 303	Flange
	Alloy 52	Core
	HNBR	O-rings
	Nickel Plated Brass	Cable gland
	FPM	Cable gland seal
M12 Connector	PUR/PVC	Cable
	PA66	Connector insert
	NBR	O-ring
Flying Leads	Silicone Rubber	Cable
		Seal



SPECIFICATIONS

ELECTRICAL

SUPPLY VOLTAGE	5Vdc \pm 0.1Vdc and 8-30Vdc unregulated – auto-selects
SUPPLY CURRENT	<80mA
SUPPLY REVERSE POLARITY PROTECTION	Yes
OVER-VOLTAGE PROTECTION	40Vdc max.
POWER-ON SETTLEMENT TIME	<1s

VOLTAGE OUTPUT – ICT800

ACTUAL ELECTRICAL STROKE = High Voltage Position – Low Voltage Position

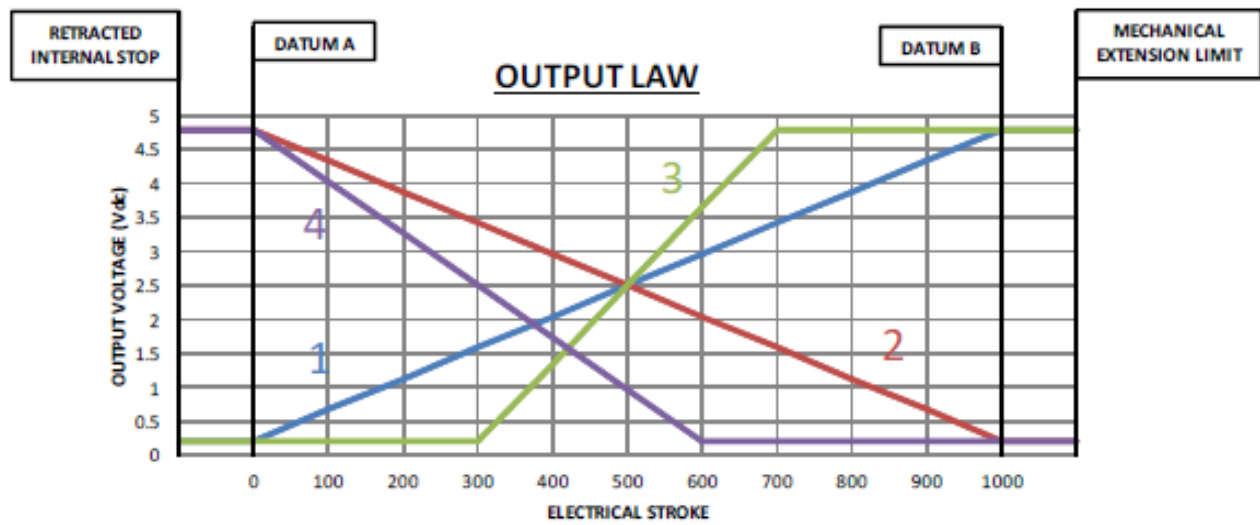

	Low Voltage Output Position	High Voltage Output Position	Actual Electrical Stroke
1	0000	0000	1000
2	1000	0000	1000
3	0300	0700	0400
4	0600	0000	0600

OUTPUT RANGE A1 @ 5Vdc SUPPLY	10-90% \pm 1% of Vsupply over measurement range
OUTPUT RANGE A1 @ 8-30Vdc SUPPLY	0-5-4.5V \pm 3% absolute
OUTPUT RANGE A5 @ 5Vdc SUPPLY	4-96% \pm 1% of Vsupply over measurement range
OUTPUT RANGE A5 @ 8-30Vdc SUPPLY	0.2-4.8V \pm 3% absolute
LOAD RESISTANCE	1k Ω min. (resistive to GND)
RESOLUTION	12-bit
LINEARITY	< \pm 0.1%
OUTPUT NOISE	<1 mV rms
INPUT/OUTPUT DELAY	<10mS
FREQUENCY RESPONSE	100Hz @ -3db
TEMPERATURE COEFFICIENT	\leq \pm 300ppm/ $^{\circ}$ C
SHORT-CIRCUIT PROTECTION	All connections except Vsupply to Output 10V max.



CAN OUTPUT – ICT820

ACTUAL ELECTRICAL STROKE = High Signal Position – Signal Position

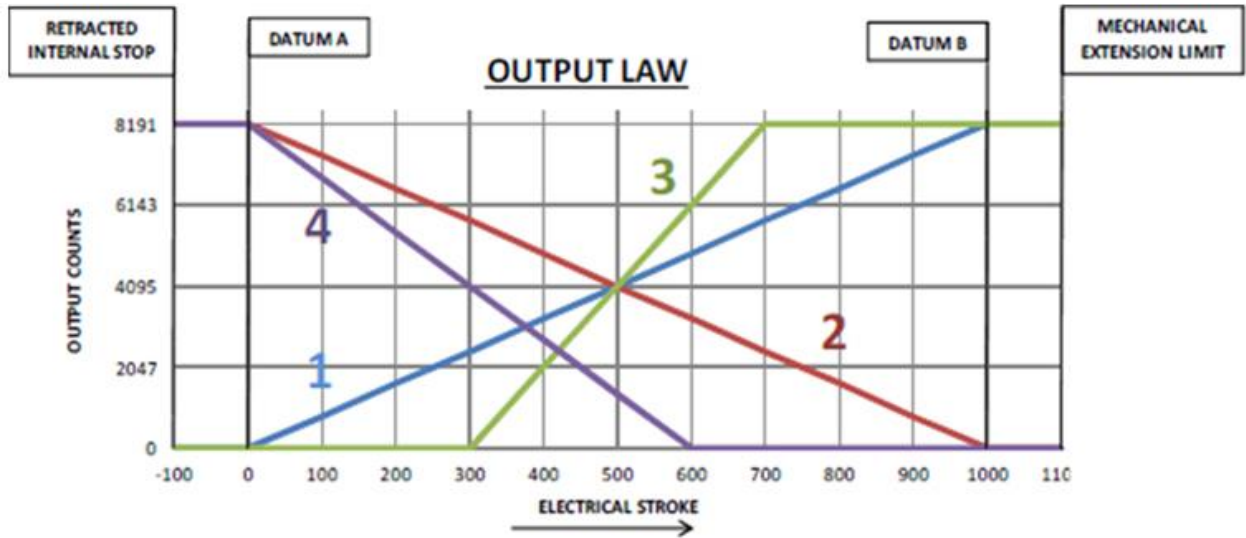

	Low Signal Output Position	High Signal Output Position	Actual Electrical Stroke
1	0000	0000	1000
2	1000	0000	1000
3	0300	0700	0400
4	0600	0000	0600

OUTPUT	J1939
RESOLUTION	13-bit
LINEARITY	<±0.1%
OUTPUT NOISE	±1-bit
INPUT/OUTPUT DELAY	= selected Frame Rate
TEMPERATURE COEFFICIENT	≤±300ppm/°C
SHORT-CIRCUIT PROTECTION	All connections except Vsupply to NC 10 Vdc max.
TEMPERATURE OUTPUT	<±3°C over temperature range
SENSOR FAULT DETECTION	Open- or short-circuit of coil
END OF TRAVEL WARNING MESSAGE	<3% or >97% of actual electrical stroke
END OF TRAVEL ERROR MESSAGE	<1% or >99% of actual electrical stroke

**ENVIRONMENTAL**

OPERATING TEMPERATURE RANGE	-40°C to 125°C (-40°C to 105°C for BXX cable)
STORAGE TEMPERATURE RANGE	-40°C to 85°C (limited by packing material)
LIFE	Contactless
MTTFd	203 years
VELOCITY MAX.	2m/s in hydraulic applications (ISO VG32 mineral oil)
VIBRATION	EN 60068-2-4 (9gn rms)
SHOCK	2500g survival
WORKING PRESSURE	670 bar
BURST PRESSURE	1000 bar
PULSED PRESSURE	0-470 bar in 1s (tested to 100,000 cycles)
WORKING FLUIDS	Compatible with a wide range of hydraulic fluids, including mineral, synthetic, fire retardant and ECO based fluids
EMC	Directive 2004/108/EC
SEALING	M12 connector (C01) IP67 Cable with gland (BXX) IP69K Flying leads (FXX) IP66

INSTALLATION GUIDELINES FOR INTERNAL FLANGE

These are guidelines intended to aid reliable installation and must be used in combination with Instruction Document, AI209399, which is supplied with each sensor.

1. Use a suitable cord through a short piece of rubber tube as shown below.

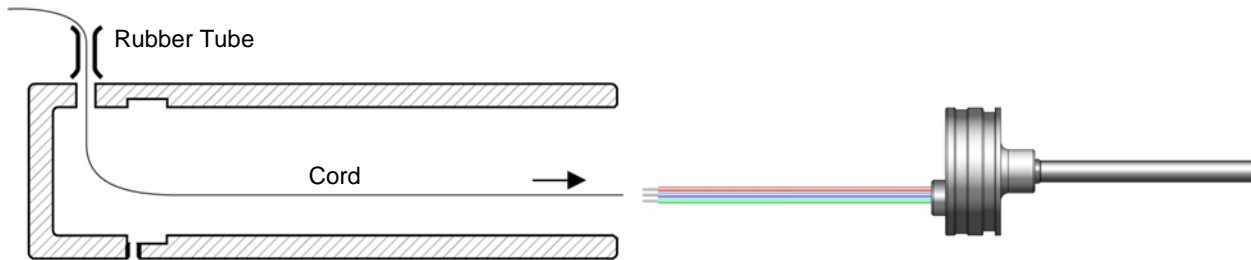

2. Fix the cord to the sensor leads and ensure the rubber tube is positioned to protect the leads, as shown below. Use a plastic tube of suitable dimensions to push the sensor into the cylinder while gently pulling the cord to keep it taut. **Do not pull the sensor into position with the cord.**

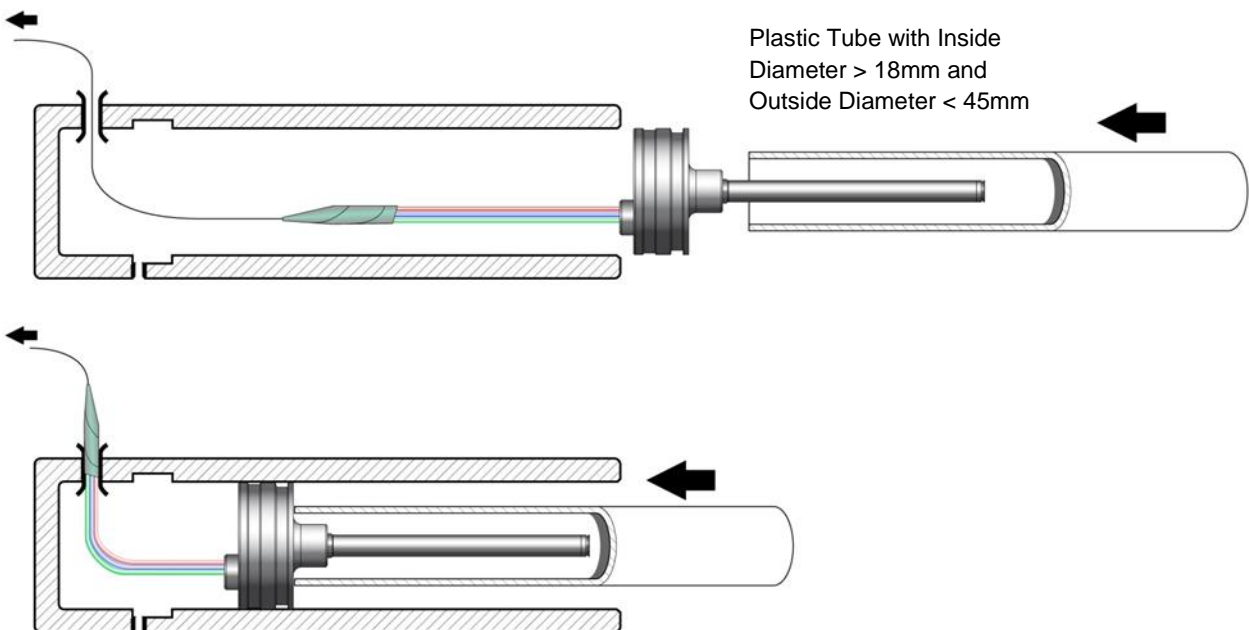



3. When the sensor is correctly positioned, remove cord, rubber tube and plastic tube. Secure sensor with screw as described in AI209399.

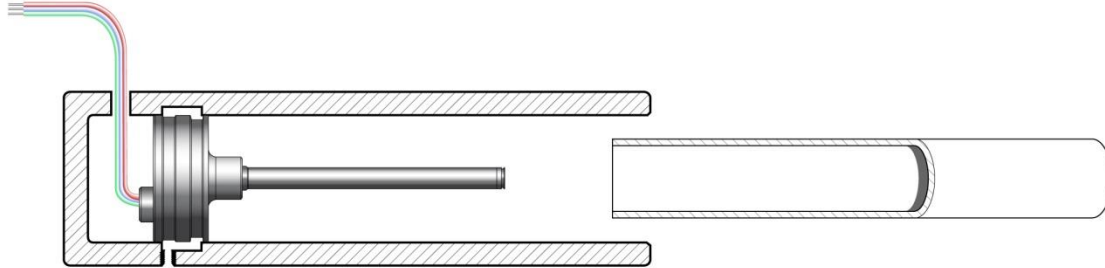

IMPORTANT INFORMATION

Whilst Curtiss-Wright Industrial Group - Penny & Giles has designed this sensor to meet a range of applications it is the responsibility of the customer to ensure it meets their specific requirement.

Penny & Giles Controls Ltd makes no warranty or representation in respect of product fitness or suitability for any particular design application, environment, or otherwise, except as may subsequently be agreed in contract for the sale and purchase of products. Customers should therefore satisfy themselves of the actual performance requirements and subsequently the product's suitability for any particular design application and the environment in which the product is to be used.

Continual research and development may require change to products and specification without prior notification.

All trademarks acknowledged.