

Non-Rotary Torque Sensors

>Model TCN

A static torque sensor for measurement of torque of stationary objects or within a certain angle rotation. Suitable for torque measurement of various automobile parts, pneumatic and electric screwdriver etc.

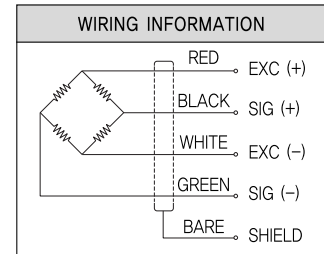
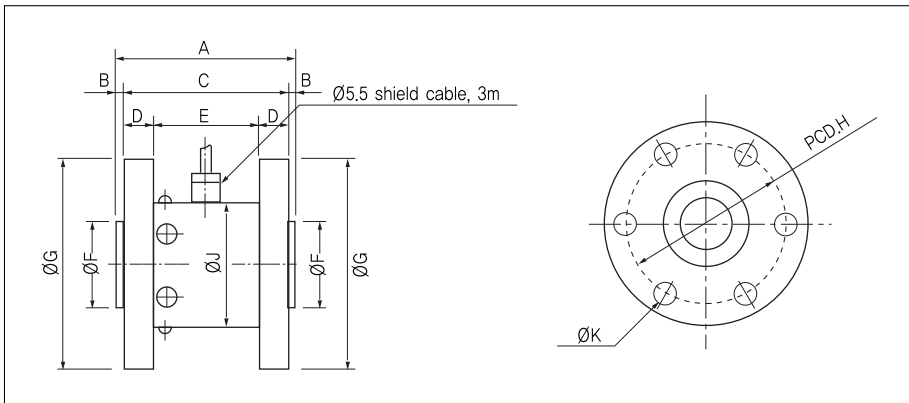
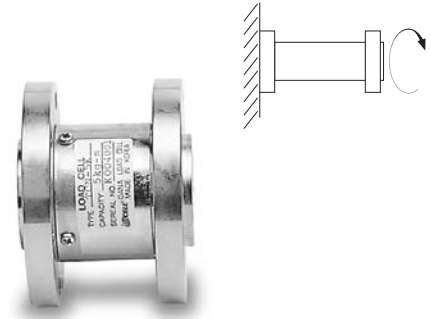

>SPECIFICATIONS

Specifications	Accuracy
Rated capacity(R.C.)	2~50kgf-cm (0.196N-m~4.903N-m), 1~2000kgf-m (9.807N-m~19.61kN-m)
Rated output(R.O.)	1mV/V±1%
Nonlinearity	0.3% (0.1kgf-m under 0.5% R.O.)
Hysteresis	0.3% (0.1kgf-m under 0.5% R.O.)
Repeatability	0.02% of R.O.
Terminal resistance, input	350Ω ±1%
Terminal resistance, output	350Ω ±1%
Insulation resistance	2000MΩ
Temperature effect on zero balance	±0.1% R.O./10°C
Temperature effect on rated output	±0.1% Load/10°C
Excitation recommended	10V DC
Safe overload	120% R.C.
Cable length	Ø5.5 4core cable, 3m

>DIMENSIONS TABLE

unit:mm

Model	Capacity	A	B	C	D	E	ØF	ØG	H	J	ØK
TCN-2KC	2kgf-cm (0.196N-m)	61	3	55	5	45	20	58	46	33	2×4-Ø4.5
TCN-3KC	3kgf-cm (0.294N-m)	61	3	55	5	45	20	58	46	33	2×4-Ø4.5
TCN-5KC	5kgf-cm (0.490N-m)	61	3	55	5	45	20	58	46	33	2×4-Ø4.5
TCN-10KC	10kgf-cm (0.981N-m)	61	3	55	10	35	40	80	66	48	2×4-Ø6.5
TCN-20KC	20kgf-cm (1.961N-m)	61	3	55	10	35	40	80	66	48	2×4-Ø6.5
TCN-30KC	30kgf-cm (2.942N-m)	61	3	55	10	35	40	80	66	48	2×4-Ø6.5
TCN-50KC	50kgf-cm (4.903N-m)	61	3	55	10	35	40	80	66	48	2×4-Ø6.5
TCN-1K	1kgf-m (9.807N-m)	61	3	55	10	35	40	80	66	48	2×4-Ø6.5
TCN-2K	2kgf-m (19.61N-m)	61	3	55	10	35	40	80	66	48	2×4-Ø6.5
TCN-3K	3kgf-m (29.42N-m)	61	3	55	10	35	40	80	66	48	2×4-Ø6.5
TCN-5K	5kgf-m (49.03N-m)	61	3	55	10	35	40	80	66	48	2×4-Ø6.5
TCN-10K	10kgf-m (98.07N-m)	61	3	55	10	35	40	80	66	48	2×4-Ø6.5
TCN-20K	20kgf-m (196.1N-m)	86	3	80	15	50	40	98	78	58	2×6-Ø10.5
TCN-50K	50kgf-m (490.3N-m)	130	3	124	20	84	60	118	95	68	2×6-Ø10.5
TCN-100K	100kgf-m (980.6N-m)	136	3	130	20	90	60	146	115	75	2×6-Ø13
TCN-200K	200kgf-m (1.961kN-m)	146	3	140	25	90	60	166	130	99	2×8-Ø17
TCN-500K	500kgf-m (4.903kN-m)	176	3	170	35	100	60	197	155	98	2×12-Ø17
TCN-1000K	1000kgf-m (9.807kN-m)	180	3	174	37	100	90	248	180	110	2×12-Ø21
TCN-2000K	2000kgf-m (19.61kN-m)	180	3	174	37	100	90	248	180	128	2×12-Ø21

★Specifications are subject to change without notice.