



APPLIED MEASUREMENTS LTD.
Transducer Specialists...

+44 (0) 118 981 7339
info@appmeas.co.uk
https://appmeas.co.uk

Universal Load Cell | Universal S-Beam Force Sensor | DBBSM

Accurate & Robust Force and Load Measuring - up to 5000kg IN STOCK

- **Lead Time:** up to 5000kg IN STOCK
Other ranges: 10 weeks
- **Buy online:** <https://appmeas.co.uk/shop/load-cells/dbbsm/>



At a Glance

- Capacities: 0-1kg up to 0-30,000kg
- Output: 2mV/V to 2.7mV/V
- Environmental Protection: IP51
- High Accuracy: $< \pm 0.03\%/RC$
- Custom Versions Available

- **Guaranteed High Performance** – With dual bending beam and shear web designs.
- **Optional IP67 Sealing for Harsh Environments**
- **Fully Submersible Versions Available** – For marine and offshore applications.
- **Fast and Simple to Install** – With standard or customised mounting bases and design fixtures.
- **Rod Ends and Load Buttons Available**

Description

Applied Measurements DBBSM universal load cell is suitable for tension or compression. It lends itself to a wide force and load measurement applications such as those found on tensile testing machines, suspended hoppers and geotechnical test equipment, as well as a wide range of other general purpose applications.

Our s-beam load cells are available to buy online from our webshop, with the 0-5000kg ranges in stock.



APPLIED MEASUREMENTS LTD.

Transducer Specialists...

+44 (0) 118 981 7339
info@appmeas.co.uk
<https://appmeas.co.uk>

Buy S-Beam Load Cell Online

Our universal load cell features a dual bending beam sensing design on all capacities up to 1000kg, while a shear web sensing design is used from 2500kg upwards. Both designs offer excellent accuracy and are guaranteed to meet a specification of $\pm 0.03\%$ of the rated capacity or better.

Applied Measurements rod-end bearings and load buttons are available (see gallery images) to suit all universal load cell capacities and provide optimal loading conditions to ensure that you get the best possible performance from your measuring system. Plus, our expert knowledgeable team can customise the DBBSM s-beam load cell to suit your specific application.

If you need to fit into a restricted space, our DBBSMM range of miniature S-Beam load cells (<https://appmeas.co.uk/products/load-cells-force-sensors/miniature-s-beam-load-cell-dbbsmm/>) will fit the bill.

“

We chose Applied Measurements' DBBSM s-beam load cells as the pigment is £1000 per tonne so has to be extremely accurate.

”

Paul Akers, Works Manager, PD Edenhall Ltd Universal Load Cell | Universal S-Beam Force Sensor | DBBSM May 31, 2018

“

For our new larger mast range with large head loads we needed an instrument with a higher range up to 500kg and in a hurry, so that's how we decided upon your product.

”

Gwyn Evans, Clark Masts Systems Limited Universal Load Cell | Universal S-Beam Force Sensor | DBBSM January 21, 2016

Technical Specifications

Rated Capacity (RC)	kgf	0-1, 0-2, 0-5, 0-10, 0-25, 0-50, 0-100, 0-250, 0-500, 0-1000, 0-2500, 0-5000, 0-10000, 0-20000, 0-30000
Operating Modes		Tension/Compression/Tension & Compression
Sensitivity (RO)	mV/V	2.7 nominal (2.0 nominal on 10000kgf>)
Zero Balance/Offset	$\pm\%$ /Rated Output	<1.0



APPLIED MEASUREMENTS LTD.

Transducer Specialists...

+44 (0) 118 981 7339
 info@appmeas.co.uk
<https://appmeas.co.uk>

Rated Capacity (RC)	kgf	0-1, 0-2, 0-5, 0-10, 0-25, 0-50, 0-100, 0-250, 0-500, 0-1000, 0-2500, 0-5000, 0-10000, 0-20000, 0-30000
Zero Return after 30 mins	±%/Applied Load	<0.03
Output Symmetry (tension vs. compression)	±%/Rated Output	0.1 to 0.25 typical
Non-Linearity	±%/Rated Output	<0.03
Hysteresis	% / Rated Output	<0.03
Repeatability	±%/Rated Output	<0.02
Temperature Effect on Zero	±%/Rated Output/ °C	<0.005
Temperature Effect on Sensitivity	±%/Applied Load/ °C	<0.005
Input Resistance	Ohms	375-420 nominal
Output Resistance	Ohms	340-360 nominal
Insulation Resistance	Megohms	>5000 @ 50Vdc
Excitation Voltage	Volts AC or DC	10 recommended (2-15 acceptable)
Operating Temperature Range	°C	-20 to +80
Compensated Temperature Range	°C	0 to +70
Storage Temperature Range	°C	-20 to +80
Safe Overload	% of Rated Capacity	150
Ultimate Overload	% of Rated Capacity	200
Maximum Safe Side Load	% of Rated Capacity	30
Deflection @ Rated Capacity	mm	see dimensional table
Fundamental Resonant Frequency*	Hz	see dimensional table
IP Rating (Environmental Protection)		IP51 (IP67 optional 50kg capacity and higher only)
Weight (excluding cable)	kg	see dimensional table
Fatigue Life		10 ⁸ cycles typical (10 ⁹ cycles on fatigue-rated version)



APPLIED MEASUREMENTS LTD.

Transducer Specialists...

+44 (0) 118 981 7339
 info@appmeas.co.uk
<https://appmeas.co.uk>

Rated Capacity (RC)	kgf	0-1, 0-2, 0-5, 0-10, 0-25, 0-50, 0-100, 0-250, 0-500, 0-1000, 0-2500, 0-5000, 0-10000, 0-20000, 0-30000
Cable Length (as standard)	metres	3
Cable Type		4-core screened, PUR sheath, Ø5
Construction Material		1kg-100kg: Aluminium Alloy / 250kg-30,000kg: Stainless Steel
Resolution		1 part in 250,000 (with appropriate instrumentation)

*The resonant frequency is calculated with the body of the load cell attached to a large plate, ensuring that only the sensing element oscillates: This is vital to achieve the highest natural frequency and subsequent frequency response.

Product Dimensions

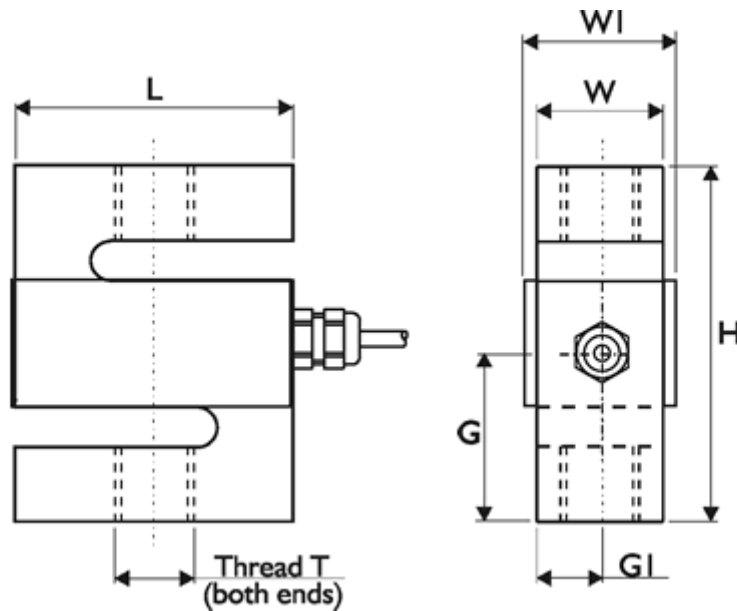

CAPACITY (kgf)	H	L	W	W1	G	G1	Threads T	Deflection mm	Weight kg	Resonant Frequency Hz
1, 2, 5, 10, 25	60	48	12.7	20	30	6.35	M8 x 1.25	0.55; 0.58; 0.51; 0.41; 0.36	0.085	94; 130; 212; 326; 536
50, 100, 250	70	48	18	25	35	9	M8 x 1.25	0.41	0.14; 0.14; 0.33	530; 740; 715
500, 1000	75	48	30	37	37.5	15	M12 x 1.75	0.41; 0.56	0.56; 0.58	760; 900
2500, 5000	90	63	38	38	45	8	M16 x 2.0	0.33; 0.43	1.33; 1.35	1200; 1700
10,000	145	138	55	N/A	72.5	27.5	M30 x 2.0	0.16	7.2	1600
20,000, 30,000	190	183	70	N/A	95	35	M45 x 3.0	0.16; 0.16	16; 16	1100; 1400



APPLIED MEASUREMENTS LTD.

Transducer Specialists...

+44 (0) 118 981 7339
 info@appmeas.co.uk
<https://appmeas.co.uk>

CAPACITY (kgf)	H	L	W	W1	G	G1	Threads T	Deflection mm	Weight kg	Resonant Frequency Hz
Note: Capacities of 10,000kg and up have rounded shoulders										

All dimensions are in mm

Wiring Details

Wire	Designation
Red	+ve excitation
Blue	-ve excitation
Green	+ve signal (tension)
Yellow	-ve signal
Screen	To ground - not connected to load cell body

Ordering Codes & Options

Core Product	Capacity (inc Engineering Units)	Cable Length (m)	Specials Code	Example Result
DBBSM	1kg	003	000	DBBSM-1kg-003-000
DBBSM	2kg	003	000	DBBSM-2kg-003-000
DBBSM	5kg	003	000	DBBSM-5kg-003-000
DBBSM	10kg	003	000	DBBSM-10kg-003-000
DBBSM	25kg	003	000	DBBSM-25kg-003-000
DBBSM	50kg	003	000	DBBSM-50kg-003-000
DBBSM	100kg	003	000	DBBSM-100kg-003-000
DBBSM	250kg	003	000	DBBSM-250kg-003-000
DBBSM	500kg	003	000	DBBSM-500kg-003-000
DBBSM	1000kg	003	000	DBBSM-1000kg-003-000
DBBSM	2500kg	003	000	DBBSM-2500kg-003-000



Core Product	Capacity (inc Engineering Units)	Cable Length (m)	Specials Code	Example Result
DBBSM	5000kg	003	000	DBBSM-5000kg-003-000
DBBSM	10,000kg	003	000	DBBSM-10,000kg-003-000
DBBSM	20,000kg	003	000	DBBSM-20,000kg-003-000
DBBSM	30,000kg	003	000	DBBSM-30,000kg-003-000

How to Install an S-Beam Load Cell

Our Applied Measurements experts have put together a 5-step guide to demonstrate how to correctly install an S-beam load cell.

Step 1 – Keep the Forces Centrally Aligned

To reduce any off-axis loading, forces must be centrally aligned through the centre of the load cell. We can supply optional load buttons and rod ends which work to reduce any side loading.

Step 2 – Do Not Overtighten the Rod Ends and Load Buttons

When using rod ends and load buttons be sure not to overtighten them when attaching them to the S-beam load cell. As this can cause damage to the load cell.

Step 3 – Always Leave a Gap

Ensure that the rod ends and load buttons do not touch the central beam. If a gap is not maintained, the central beam will not be able to move freely when tension or compressive force is applied.

Step 4 – Mount on a Flat Surface

Always secure the S-beam load cell to a clean, flat surface of better than 0.005mm surface flatness.

Step 5 – Contact with Active Area Only

When installing the S-beam load cell ensure the load is applied to the active end area only.

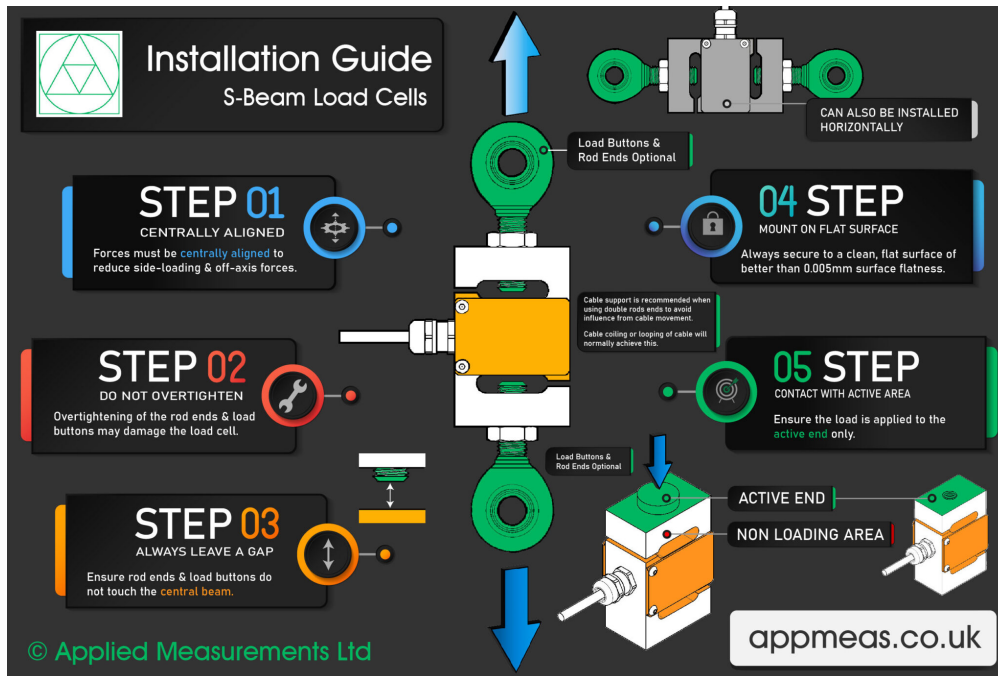

Mounting and Installation Accessories

Load Buttons and Rod End Bearings

Designed to align forces through the principle axis of the load cell thus reducing the effects of extraneous forces, hence offering improved performance from the cell.

Load buttons are used where compressive forces are applied.

Rod End Bearings are used where tensile forces are being applied.

Load Buttons for Compression Use

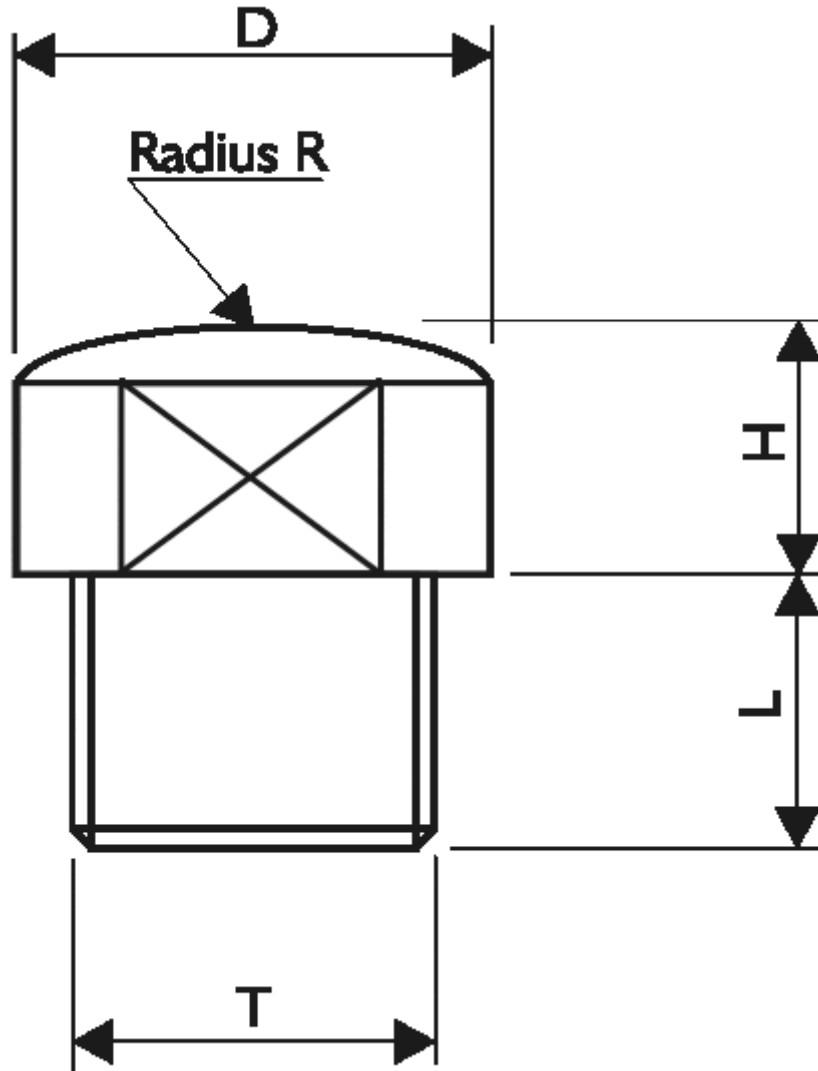

THREAD T	M8 x 1.25	M12 x 1.75	M16 x 2	M24 x 2	M30 x 2	M45 x 3
D	15	22	32	26	50	70
H	5	6	10	14	20	40
L	10	12	16	26	40	60
R	150	150	180	200	200	300

Rod End Bearings for Tension Use

- Supports radial loads in a tensile or compressive direction.



APPLIED MEASUREMENTS LTD.

Transducer Specialists...

+44 (0) 118 981 7339
info@appmeas.co.uk
<https://appmeas.co.uk>

- Suitable for unilateral loads – can support alternating loads and alternating loads in combination with bearing GE..UK-2RS.
- Zinc plated for corrosion resistance.
- Are maintenance-free (in bearings with Elgoglide®, lubricant leads to a considerable reduction in bearing life)
- Fitted with radial spherical plain bearings GE..UK or GE..UK-2RS
- Hard chromium/PTFE composite or hard chromium/Elgoglide® sliding contact surfaces.
- Enables compact adjacent construction thanks to its thin walled design of the eye housing.



GAR..UK
(right hand thread)
GAR..UK-2RS
(right hand thread)

- To ISO 12 240-4, dimension series E, type M
- Shank with external thread
- Suffix -2RS: lip seals on both sides, for operating temperatures from -30°C to +130°C
- GAR..UK and GAL..UK for shaft diameters from 6mm to 30mm
- GAR..UK-2RS and GAL..UK-2RS for shaft diameters from 35mm to 80mm

Maintenance-free
ISO 12 240-4, dimension series E, type M



APPLIED MEASUREMENTS LTD.

Transducer Specialists...

+44 (0) 118 981 7339
 info@appmeas.co.uk
<https://appmeas.co.uk>

Sliding contact surface: hard chromium/PTFE

Series GAR..UK

Sliding material: PTFE composite

GAR..UK-2RS

Sliding material: Elgoglide®

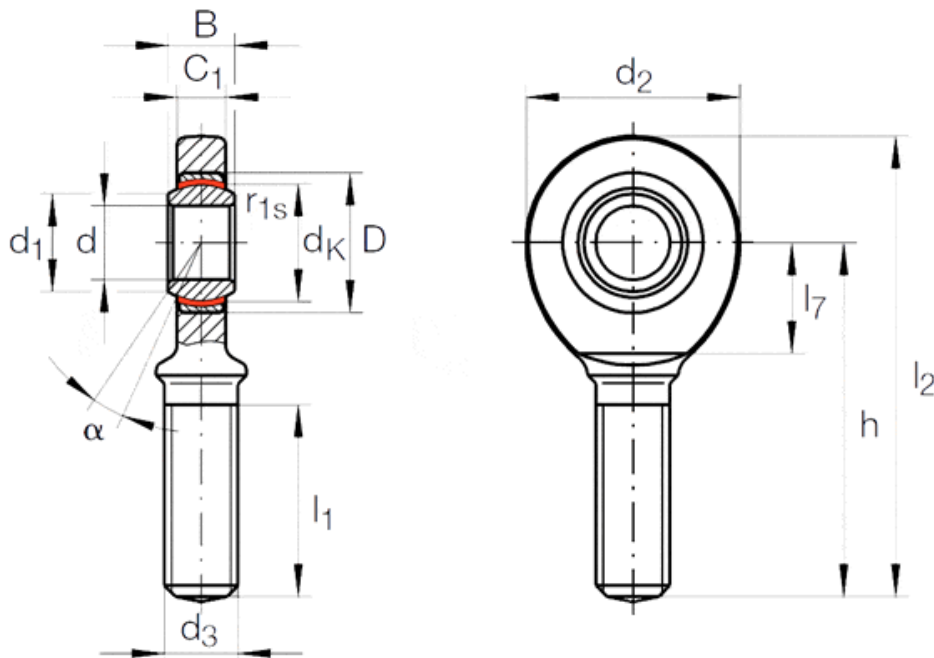

LOAD CELL	SHAFT DIAMETER	ORDERING CODE		MASS	DIMENSIONS						
		WITHOUT SEALS	WITH SEALS		d	D	B	dk	d1	d2	d3
DBBSM-1kg to 250kg	8	GAR 8 UK	-	≈ kg	8-0.008	16	8-0.12	13	10.2	24	M8
DBBSM-500kg to 1000kg	12	GAR 12 UK	-	0.086	12-0.008	22	10-0.12	18	14.9	34	M12
DBBSM-2500kg to 5000kg	17	GAR 17 UK	-	0.19	17-0.008	30	14-0.12	25	20.7	46	M16
DBBSM-10,000kg	30	GAR 30 UK	-	0.89	30-0.01	47	22-0.12	40.7	34.2	73	M30x2
DBBSM-20,000kg to 30,000kg	50	-	GAR 50 UK-2RS	3.4	50-0.012	75	35-0.12	66	55.9	112	M45 x 3

TYPE	Degrees						Chamfer Dimension	Basic Load Ratings 1)		Radial Internal Clearance	Shaft Diameter
	h	C1	α	l1	l2	l7	r1s min.	dyn. Cr N	stat. C0r N		d



APPLIED MEASUREMENTS LTD.

Transducer Specialists...

+44 (0) 118 981 7339
info@appmeas.co.uk
<https://appmeas.co.uk>

TYPE	Degrees						Chamfer Dimension	Basic Load Ratings 1)		Radial Internal Clearance	Shaft Diameter
DBBSM-5kg to 250kg	42	6	15	22	54	14	0.3	5 850	12 900	0 - 0.032	8
DBBSM-500kg to 1000kg	54	8	11	28	71	18	0.3	11 400	30 100	0 - 0.032	12
DBBSM-2500kg to 5000kg	69	11	10	36	92	23	0.3	22 400	56 500	0 - 0.04	17
DBBSM-10,000kg	110	19	6	65	146.5	37	0.6	65 500	138 000	0 - 0.05	30
DBBSM-20,000kg to 30,000kg	185	30	6	107	241	60	0.6	442 000	313 000	0 - 0.06	50

1) Basic load rating of housing.

In rod ends with the sliding material Elgoglide®, the basic load rating C_{0r} of the housing is less than the basic dynamic load rating C_r of the bearing.

Case Studies

S-Beam Load Cells Promise Accurate Pigment Dispensing



We chose Applied Measurements' DBBSM s-beam load cells as the pigment is £1000 per tonne so has to be extremely accurate" says Paul Akers, Works Manager at PD Edenhall Ltd. One of the largest independent concrete facing brick manufacturer in the UK, needed a way to accurately monitor the amount of pigment being dispensed into the weigh hopper throughout the manufacture of concrete facing bricks. The pigment amount needs to be precise as inaccurate amounts of pigment can lead to incorrect colour blends leading to a loss in sales and profit. Read how our accurate DBBSM s-beam load cells and intuitive4-L digital indicators were used in this construction industry application.

Read more... (<https://appmeas.co.uk/blog/s-beam-load-cells-promise-accurate-pigment-dispensing/>)

Complete Tensile Monitoring System Delivered in Under 1 Week



With huge capacities of up to 30,000kg and an accuracy of $< \pm 0.03\%$ of the rated capacity, the highly accurate DBBSM S-beam load cell really is the knight in stainless steel armour. Not only can it efficiently handle the larger loads in the guys, it can also be supplied in less than 1 week! Its tough construction makes it ideal to use in the harsh outdoor conditions on the guy cables.

Read more... (<https://appmeas.co.uk/blog/complete-tensile-monitoring-system/>)

Force Measurement Determines The Effect of Girth Tension on Horse Gait

Using electrical systems for the measurement of mechanical forces is by no means limited to machines and laboratory based applications. In her recently completed research thesis 'Girth Tensions and their Effects on Equine Stride Characteristics', Sue Wright of Moulton College Northampton used load cells, motion sensors and GPS amongst other technologies to measure and record the tension within the girth



APPLIED MEASUREMENTS LTD.

Transducer Specialists...

+44 (0) 118 981 7339
info@appmeas.co.uk
<https://appmeas.co.uk>



strap used to hold the saddle in place.

Read more... (<https://appmeas.co.uk/blog/force-measurement-determines-girth-tension/>)

Related Products & Services



Load Cell Digital Indicator | High Accuracy | Intuitive4-L

(<https://appmeas.co.uk/products/instrumentation/load-cell-digital-indicator-int4-l/>)



Handheld Load Cell Indicator | Digital Display | TR150

(<https://appmeas.co.uk/products/instrumentation/tr150-digital-handheld-load-cell-indicator/>)



Wireless Telemetry for Load Cells, Strain Gauge Sensors & Transducers
(<https://appmeas.co.uk/products/instrumentation/t24-wireless-telemetry/>)



Load Cell Amplifier | Load Cell Signal Conditioner | SGA

(<https://appmeas.co.uk/products/instrumentation/load-cell-amplifier-sga/>)



USB Load Cell Interface | USB Strain Gauge Digitiser |...

(<https://appmeas.co.uk/products/instrumentation/usb-load-cell-interface-strain-gauge-digitiser-dscusb/>)

View this page in a browser:



<https://appmeas.co.uk/products/load-cells-force-sensors/s-beam-universal-load-cell-dbbsm/>