



Technical data



7 INCH
DISPLAY



800 NIT
SUNLIGHT
READABLE



60/60/60/50°
VIEWING ANGLE



800
x 480
RESOLUTION



IP 67
INGRESS
PROTECTION



+ 80°
- 30°
OPERATING
TEMP



14 X ANALOGUE
INPUTS



4 X DIGITAL
INPUTS



ETHERNET



2 X USB
PORTS



8 X RELAY
OUTPUTS



1 X RS232



2 X
CAN BUS



1 X TACHO
INPUT

C7

7" COLOUR DISPLAY

FORMERLY THE CANVU™ 700, IS THE LARGEST DISPLAY IN THE RANGE WITH A HI-RESOLUTION 7 INCH TOUCH SCREEN.

The C7 has a customisable, hi-resolution, 7-inch touch-screen, that allows developers to bring together easy to read information via a simple to operate, powerful rugged interface.

The WVGA (800x480) TFT LCD colour display can be viewed in full sunlight, has the potential for multiple screens to be displayed via user defined touch screen buttons, and supports external buttons/joystick controls.

The complete unit is sealed to meet IP standards 66 (front) & 67 (rear), it meets the need for tough, flexible instrumentation that will handle the harshest environments and where a larger display is essential.

Using the powerful Freescale iMX 286 ARM processor running Linux, programmers can quickly put together a project using our proprietary software developer's kit (SDK) and the proven Veethree component based library. Application software is able to be rapidly validated on a PC using the PC simulator.

Reliability

Our products continue to be successfully deployed in an enormously diverse range of applications where total reliability is vital.

All products, bespoke or standard range are backed up by a dedicated central team of specialist engineers able to rapidly adapt any product for a specific application and to provide an unrivalled level of customer support.

Displays are also supported with a return to base extended 24-month Manufacture warranty against mechanical failure or material defects.



Software

Our SDK is offered for a one-off licence fee from which customers can develop their own bespoke application solution. Available are optional plugins for J1939, NMEA 2000, and support hours are included should your engineers need any help along the way.

Alternatively, we can develop bespoke software to your specification using our experienced in house engineers.

Over the years our engineers have developed software for our displays to run rock crushers & mining machinery, measure performance of spraying equipment, acting as battery monitors, boat gyro stabilisers, plus many more including military and aerospace applications.

Also available is our Engine Monitor standard software for Industrial and Marine, which can be pre-loaded to our displays receiving and displaying J1939 engine and transmission data, including common Tier4 parameters, with active alarms (from DM1) & NMEA 2000 data, where supported.



Accessories

- > Cable Harnesses
- > Front Mounting Kits
- > Protective Sun Covers
- > Branding - Labels & Boxes
- > GPS Sensor
- > Development Harness



Specifications

Hardware

CPU	Freescale iMX 286 (454 MHz)
FLASH Memory	128MB NAND
SDRAM	128MB

Electrical

Display	a-Si TFT LCD 7.0"
Resolution	800 (H) x 480 (V) WVGA
Active Area	152.40mm (H) x 91.44mm (V)
Viewing Angle	60 degrees left/right/down 50 degrees up
Number Of Colours	262K
Contrast Ratio	400:1
Brightness	800 NIT (cd/m ²) Fully sunlight readable
Power Requirements	10V to 32V DC
Sounder	Internal Buzzer
Connection	(3) 12 Pin Deutsch DT04-12PA / 12PB / 12PC Moulded in Receptacle Mates with DT06-12SA / 12SB / 12SC respectively

Environmental

Operating temperature	-30°C to +80°C
Storage Temperature	-40°C to +80°C
Degree of Protection	IP67 All Round, IP66 Front

Mechanical

Case material	ABS
Case colour	Anthracite Grey
Dimensions	205mm (W) x 157mm (H) x 30mm forward and 28mm rear (D)

Input/Output / Communications

14 Analogue Inputs	Software Selectable As 0 - 2.5 VDC, 0 - 10 VDC or 0 - 1000 OHMS
3 Switch Inputs	Switch Contact to ground or open collector type sensor - max. frequency = 50 Hz
RPM Input	Magnetic pick up or hall effect & similar with push-pull output - max. frequency = 5 KHz
8 Relay / Solenoid Outputs	Open collector suitable 0.5A continuous load.
Communications	1 X RS232, 2 X CAN Bus 2.0B (1 isolated), 2 x USB, Ethernet (100BASE-TX)

Part Number

7000	C7 7" CAN Display
7001	C7 7" CAN Display with Engine Monitor Software Preloaded



Connectors (Version No. 06)

Primary		Secondary		Tertiary	
1	Ground	1	Sensor 1 Analogue Input	1	Sensor 8 Analogue Input
2	Power	2	Sensor 2 Analogue Input	2	Sensor 9 Analogue Input
3	Relay/Solenoid Output 1	3	Sensor 3 Analogue Input	3	Sensor 10 Analogue Input
4	Relay/Solenoid Output 2	4	Sensor 4 Analogue Input	4	Sensor 11 Analogue Input
5	Isolated CAN Supply (-)	5	Sensor 5 Analogue Input	5	Sensor 12 Analogue Input
6	Isolated CAN Supply (+)	6	Sensor 6 Analogue Input	6	Sensor 13 Analogue Input
7	Isolated CAN Data H	7	Sensor 7 Analogue Input	7	Sensor 14 Analogue Input
8	Isolated CAN Data L	8	Digital Input	8	Digital Input
9	Relay/Solenoid Output 3	9	Digital Input	9	Relay/Solenoid Output 5
10	Relay/Solenoid Output 4	10	Tachometer Input	10	Relay/Solenoid Output 6
11	Primary CAN Data L	11	RS232 Receiver	11	Relay/Solenoid Output 7
12	Primary CAN Data H	12	RS232 Transmit	12	Relay/Solenoid Output 8

Mates With DT06-12SA

Mates With DT06-12SB

Mates With DT06-12SC

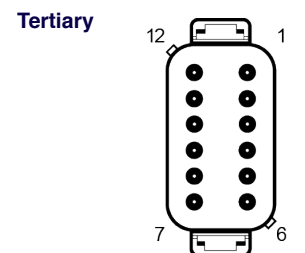
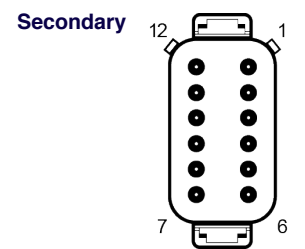
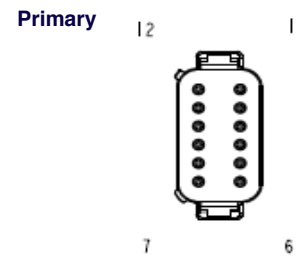

Note 1. (10-32V DC) Supply should be protected by 2A – Rated circuit breaker/fuse.

IMPORTANT NOTICE

Safety Warning: Please note analogue input voltages should not exceed the supply voltage or damage may occur. No power should be present on the harness during connection. USB port should not be used for charging external equipment such as mobile phones.

Connect Harness 1 (Primary) noting correct orientation of connector. Ensure it is fully mated so the connector latches into place. Then connect Harness 2 (Secondary) note correct orientation of connector. Ensure it is fully mated so the connector latches into place. Repeat with Harness 3.

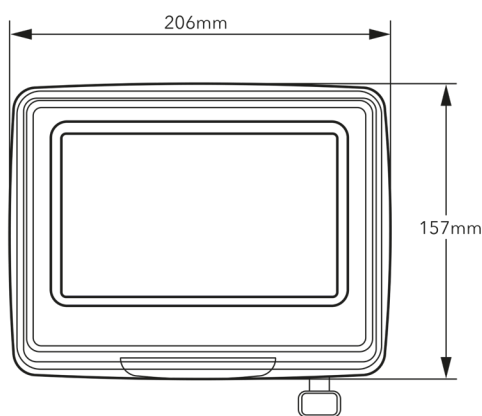
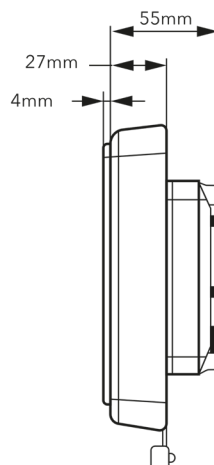
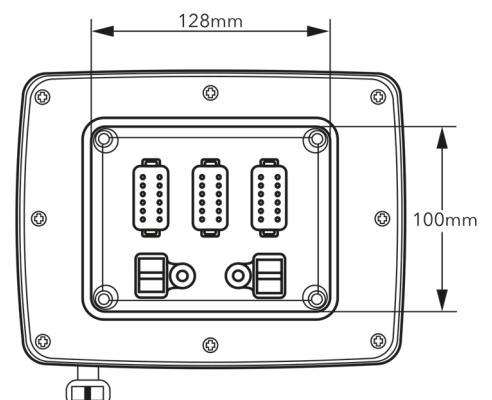
Dimensions
FRONT VIEW

SIDE VIEW

REAR VIEW

2021 v1